



INSTRUCTION MANUAL

Air operated double diaphragm pumps

Ver. 3.25

Models: DM 15/25

DM 20/75

DM 25/125

DM 40/315

DM 50/565

DM 80/850

Serial no.

DECLARATION OF CONFORMITY

Directive 2006/42/EC, Annex 2A

Company: **DELLMECO LTD**

Address: **Unit 1, Willow Row
Longton, Stoke on Trent
Staffordshire, ST3 2PU, United Kingdom**

declares under our sole responsibility, that the product:

Product name: **Air Operated Double Diaphragm Pumps**

Models: **DM - series**

Referred to in this declaration conforms with the:

- Directive 2006/42/EC

Date: **December 2nd 2013**

A handwritten signature in black ink, appearing to read 'K. Ziemann', with a stylized flourish at the end.

**K. Ziemann
Managing Director**

Table of contents

1. Introduction	4
2. For safe operation	4
3. Warnings and cautions	4
4. Operating caution	4
5. Names of parts and materials	6
5.1. DM 15/25	6
5.2. DM 20/75, DM 25/125	8
5.3. DM 40/315, DM 50/565	10
5.4. DM 80/850 (Aluminium version only)	12
6. Assembly	14
7. Installation	14
7.1. Installing the pump	14
7.2. Connecting the ground wire	16
8. Connection	16
8.1. Connecting fluid piping	16
8.2. Connecting air piping	17
9. Operation	18
9.1. Method of operation	18
9.2. Flow adjustment	18
9.3. Shutdown	19
10. Method of cleaning	19
11. Daily check	20
12. Possible problems	20
13. Returning the product for servicing	22
14. Main body specification	24
14.1. Main specification	24
14.2. Appearance and dimensions	24
14.3. Technical Data	25
14.4. Pump code	25
14.5. Performance curves	26
15. Dellmeco Active Pulsation Dampers for Metal Pumps	27
15.1. Main specification	27
15.2. Appearance and dimensions	30
16. Optional Equipment	31
16.1. Barrier Chamber System (option code BC1, BC2, BC3)	31
16.2. Stroke Counting (option code SC1, SC2, SC3, SC5, SC6)	33
16.3. Diaphragm Monitoring (option code DM1, DM2)	35
16.4. Flange Connections (option code F4, F7, F8, F9)	35
16.5. Sleeve with Split Connections (option code S)	35
16.6. Back Flushing System (option code BF1, BF2, BF3)	36
16.7. High Pressure (option code HP)	37
16.8. Heating Jacket (option code HJ) - AISI 316 only	40
16.9. Powder Pump (option code P) – Aluminium only	41
17. Limited warranty	42

1. Introduction

This pump is a positive-displacement pump that transfers fluids by means of diaphragms movement operated by compressed air. The casing in contact with the fluid is made of Aluminium (Al), Aluminium coated with PTFE (Al + PTFE), AISI316, or Cast Iron (CI).

2. For safe operation

This document contains information indispensable for maintaining safe and efficient operation of this product. Read this document carefully before using the pump, particularly the "Warnings and cautions". Get familiar with all operating procedures. This document must be kept handy for future reference.

3. Warnings and cautions

The meanings of warning and caution symbols are given below. Be sure to remember their meanings.



WARNING:

ignoring the caution and operate the product in an improper manner can result in danger of serious bodily injury or death.



CAUTION:

ignoring the caution and operate the product in an improper manner can result in danger of personal injury or property damage.



This symbol means a "DON'T", and will be followed by an explanation on what you must not do.



This symbol means a "DO", and will be followed by an explanation on what you must do in a specified situation.

4. Operating caution

Before using this product



WARNING



To drive the pump you must use one of the following compressed gases (called in this document "compressed air"):

- Compressed air supplied from air compressor
- Nitrogen (N₂) gas

Use of compressed air other than the above may cause air pollution, damage to the pump, or even an explosion.



The maximum permissible pressure for the compressed air, and the fluid pumped by one of its pumps is 8 bars. Should the above applicable maximum permissible pressure be exceeded, the following results may follow: damage to the casing, or even a severe, possibly fatal accident. In some pump executions, specified by manufacturer, the max. pressure can reach 14 bars.



In case a diaphragm gets damaged, fluid will gush out together with air through the exhaust port. Provide protective measures in consideration of possible leakage of fluid. When you using the hose and pit etc, make sure to use a model with appropriate corrosion resistance for the fluid to be pumped.



WARNING

- ! When installing this product, be sure to connect a ground wire from the specified position of this product. Otherwise friction between parts and abrasion caused by the flow of some fluids inside the casing may generate static electricity. Depending on the type of fluid being pumped and the installation environment (such as gases in the air and type of surrounding mixtures), static electricity could cause fire or electric shock.
- ! Some fluid may remain inside the pump and inside the connected piping after shutting down the pump, or if the pump is left unused for a prolonged period. Therefore, be sure to purge the system of fluid and clean the pump before prolonged disuse. The fluid remaining in the connected piping as well as the pump itself may expand because of freezing or heat which may cause damage to the pump or/and piping and lead to leakage of the fluid.
- ∅ Use only genuine Dellmeeco parts when replacing component parts of this product.
- ! Torque of all tightening parts must be checked before running the pump. Designated torques are mentioned in maintenance manual. Valve ball stoppers in all metal pumps, except DM 80/850, are thread-mounted with additional use of LOCTITE 243 Medium Strength Threadlocker. When assembling valve ball stoppers, you have to use LOCTITE 243 product necessarily to reinforce the connection.
- ! In case of pumping a hazardous fluid (hot, flammable, strong acid, etc.) with this pump, protective measures (install a pit, a protection box, sensors, etc.) must be provided in consideration of possible leakage of fluid. Warning signs must be displayed at necessary places. Leakage of fluid may cause fire or accident.
- ! Before using this pump, get fully familiar with the precautions regarding the fluid to be pumped, and verify the corrosion resistance of the parts that will come into contact with the fluid. NEVER use the pump with any fluid against which it does not have sufficient corrosion resistance or with a fluid that poses a risk of explosion. If you are unable to verify the corrosion resistance, contact your dealer. Using this product with any fluid against which the parts in contact with the fluid do not have sufficient corrosion resistance may result in damaging the product or leakage of fluid.



CAUTION

- ! The running pump may generate loud operating noise. Its level will vary depending upon the conditions of use (fluid pumped, supply air pressure and discharge pressure)
- ! To drive this product, supply air with minimum moisture content and without any oil must be used.
- ! If a diaphragm of this pump is damaged, supply air may mix with the fluid or the fluid may flow into the central housing. DO NOT OPERATE THE PUMP if air supply is inadequate or contaminated.
- ∅ While operating this product, do NOT put your hand on the inlet port.

5. Names of parts and materials

5.1. DM 15/25

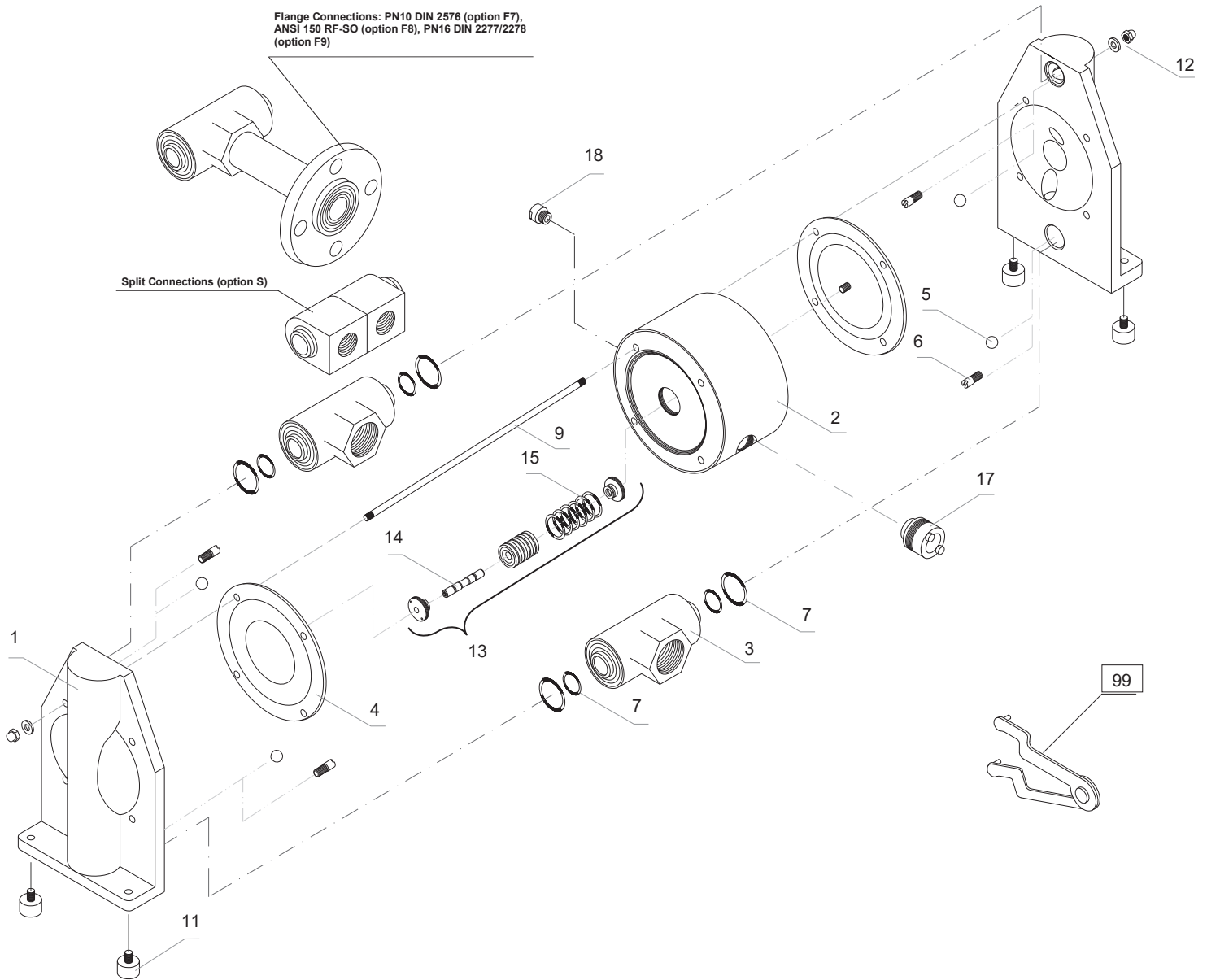

Spare parts list for DM 15/25 pumps

			MATERIAL	DM 15/25
1.	2	Pump housing	Al	3 15 01 60
			Al + PTFE	3 15 01 61
			Cast iron	3 15 01 65
2.	1	Center housing	PE conductive	1 10 10 21
3.	2	Suction/Discharge ports	Al	3 15 30 60
			AISI 316L	3 15 30 53
			Cast iron	3 15 30 65
			Suction/Discharge ports-twin (Split Connections)	Al
	1	Suction port-drum	Al	3 15 33 60
4.	2	Diaphragm	TFM (PTFE)	1 10 50 05
			EPDM	1 10 50 08
			NBR	1 10 50 10
			EPDM/TFM/PFA	1 10 50 00
5.	4	Valve balls	PTFE	1 10 60 23
			EPDM	1 10 60 08
			NBR	1 10 60 10
			AISI 316	1 10 60 52
			Ceramic	1 10 60 90
6.	4	Valve ball stopper	AISI 304	3 15 39 50
			AISI 316	3 15 39 52
7.	4	Sealing inlet/outlet – complete	NBR	3 15 70 10
			EPDM	3 15 70 08
9.	4	Housing bolt	AISI 304	3 15 42 50
11.	4	Shock absorber	NR/St37	1 10 69 06
12.	8	Nut with washer	AISI 304	1 10 45 59
13.	1	Air valve	PET/NBR	1 08 020 31
			PET/FKM	1 08 020 32
14.	1	Shaft	AISI 304	1 08 24 50
15.	6	O-ring, air valve	NBR	1 08 080 10
			FKM	1 08 080 09
17.	1	Muffler	PE porous	1 08 99 35
			BZ	1 08 99 86
18.	1	Air adapter	PP	1 08 46 28
20.	1	Tube	PP	1 10 96 28
			Al	1 10 96 60
			AISI 316	1 10 96 52
35.	1	Center housing complete	PE conductive	1 10 11 21
99.	1	Air valve key (SK4)	diverse	1 08 58 00

5.2. DM 20/75, DM 25/125

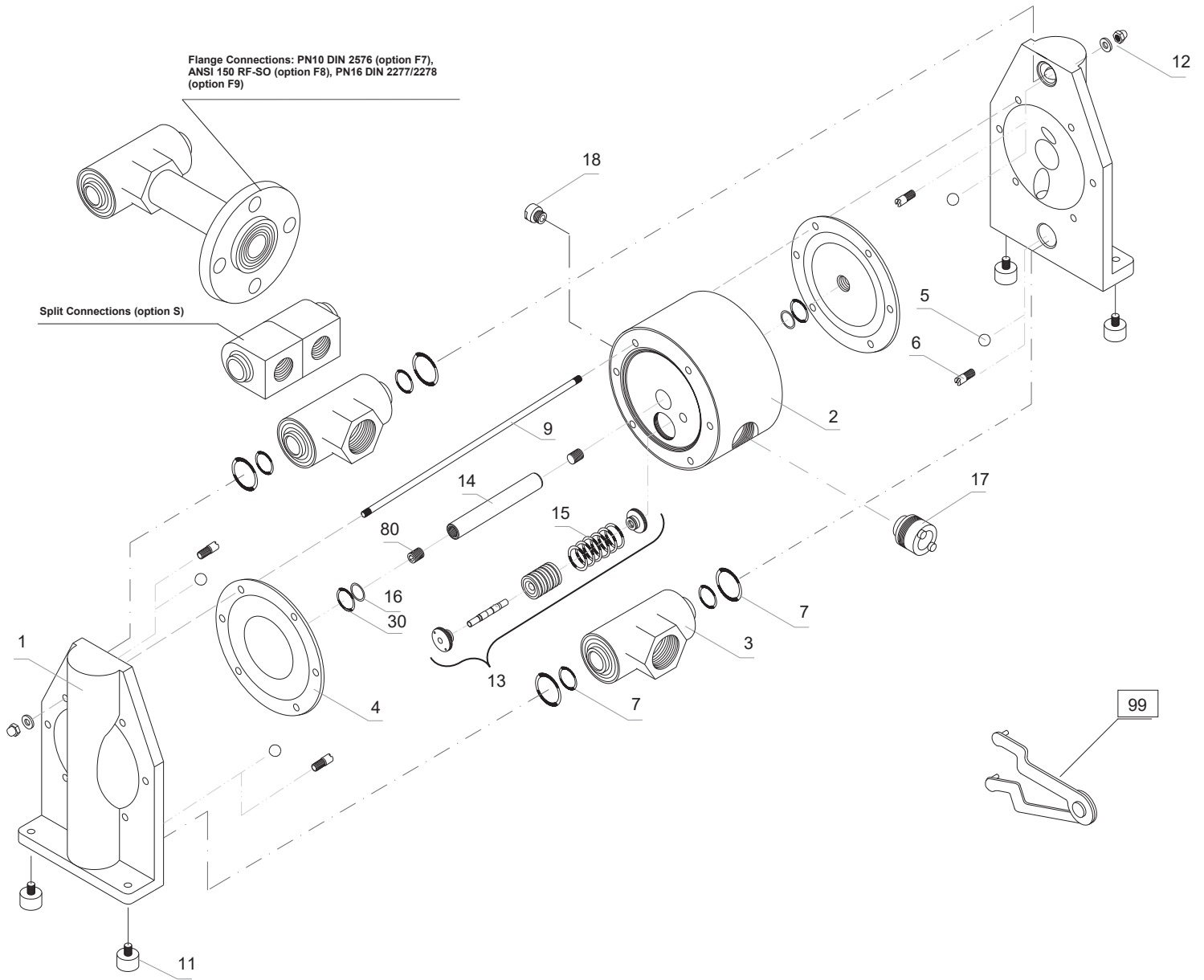

Spare parts list for DM 20/75 and DM 25/125 pumps

			MATERIAL	DM 20/75	DM 25/125
1.	2	Pump housing	Al	3 20 01 60	3 25 01 60
			Al + PTFE	3 20 01 61	3 25 01 61
			AISI 316	3 20 01 52	3 25 01 52
			Cast iron	3 20 01 65	3 25 01 65
2.	1	Center housing	PE conductive	1 15 10 21	1 25 10 21
3.	2	Suction/Discharge ports	Al	3 20 30 60	3 25 30 60
			AISI 316	3 20 30 52	3 25 30 52
			Cast iron	3 20 30 65	3 25 30 65
		Suction/Discharge ports-twin (Split Connections)	Al	3 20 31 60	3 25 31 60
			AISI 316	3 20 31 52	3 25 31 52
	1	Suction port-drum	Al	3 20 33 60	3 25 33 60
AISI 316			3 20 33 52	3 25 33 52	
4.	2	Diaphragm	TFM (PTFE)	1 15 50 05	1 25 50 05
			EPDM	1 15 50 08	1 25 50 08
			NBR	1 15 50 10	1 25 50 10
			EPDM/TFM/PFA	1 15 50 00	-
5.	4	Valve balls	PTFE	1 15 60 23	1 25 60 23
			EPDM	1 15 60 08	1 25 60 08
			NBR	1 15 60 10	1 25 60 10
			AISI 316	1 15 60 52	1 25 60 52
			Polyurethane	1 15 60 07	1 25 60 07
			Ceramic	1 15 60 90	1 25 60 90
6.	4	Valve ball stopper	AISI 304	3 20 39 50	3 25 39 50
			AISI 316	3 20 39 52	3 25 39 52
7.	4	Sealing inlet/outlet – complete	NBR	3 20 70 10	3 25 70 10
			EPDM	3 20 70 08	3 25 70 08
			FEP/FKM	3 20 70 04	3 25 70 04
9.	6	Housing bolt	AISI 304	3 20 42 50	3 25 42 50
11.	4	Shock absorber	NR/St37	1 15 69 06	1 25 69 06
			NR/AISI 304	1 15 69 52	1 25 69 52
12.	12	Nut with washer	AISI 304	1 15 45 59	1 25 45 59
13.	1	Air valve	PET/NBR	1 15 020 31	1 15 020 31
			PET/FKM	1 15 020 32	1 15 020 32
14.	1	Shaft	AISI 304	1 15 40 50	1 25 40 50
15.	6	O-ring, air valve	NBR	1 15 080 10	1 15 080 10
			FKM	1 15 080 09	1 15 080 09
16.	2	Center housing seal	PE	1 15 85 22	1 25 85 22
17.	1	Muffler	PE porous	1 15 99 35	1 15 99 35
			BZ	1 08 99 86	1 08 99 86
18.	1	Air adapter	PP	1 15 46 28	1 15 46 28
20.	1	Tube	PP	1 15 96 28	1 25 96 28
			Al	1 15 96 60	1 25 96 60
			AISI 316	1 15 96 52	1 25 96 52
30.	2	O-ring for center housing seal	NBR	1 15 85 10	1 25 85 10
35.	1	Center housing complete	PE conductive	1 15 11 21	1 25 11 21
80.	2	Shaft allen pin screw	AISI 304	1 15 540 50	1 25 540 50
99.	1	Air valve key (SK4)	diverse	1 08 58 00	1 08 58 00

5.3. DM 40/315, DM 50/565

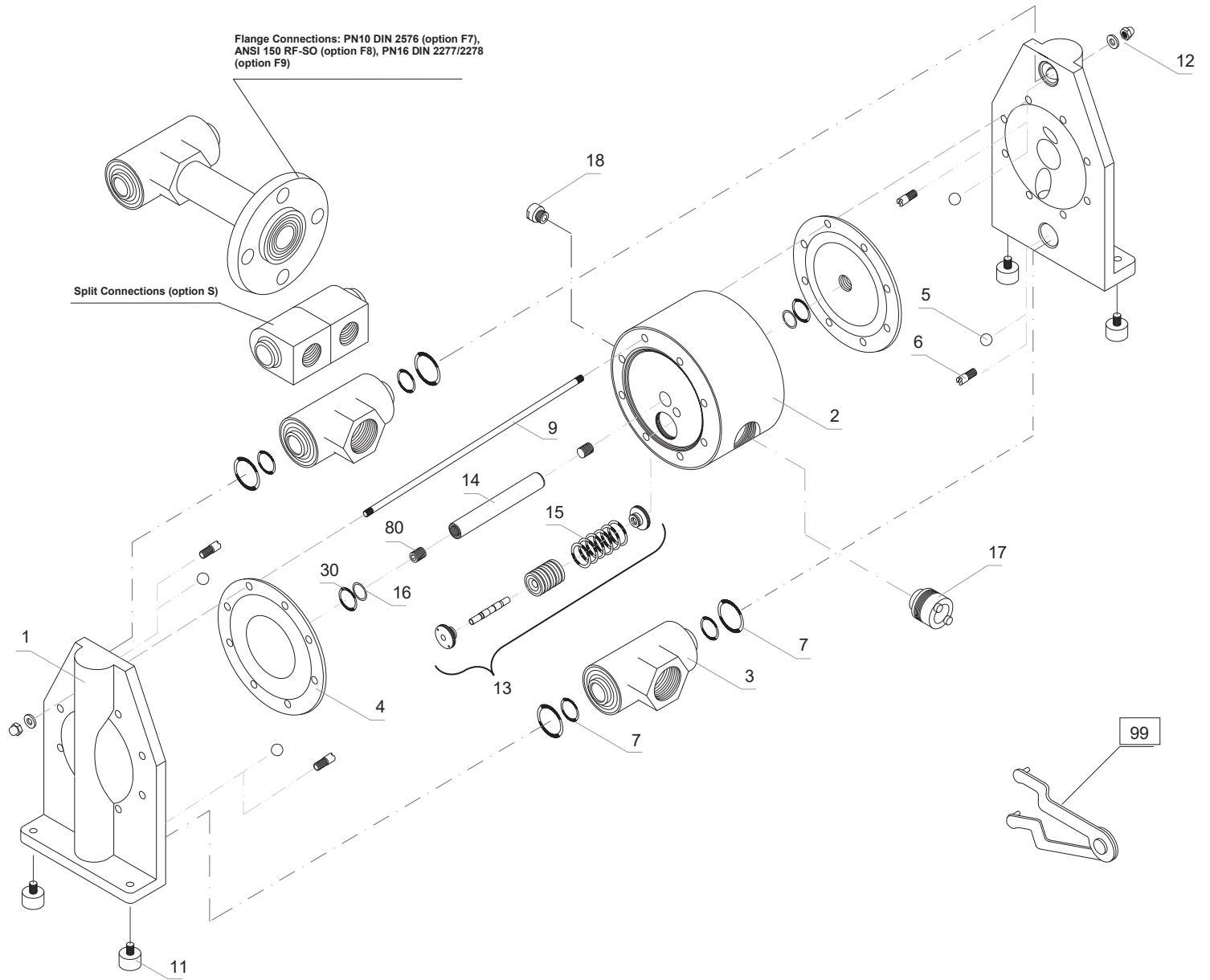

Spare parts list for DM 40/315 and DM 50/565 pumps

			MATERIAL	DM 40/315	DM 50/565
1.	2	Pump housing	Al	3 40 01 60	3 50 01 60
			Al+PTFE	3 40 01 61	3 50 01 61
			AISI 316	3 40 01 52	3 50 01 52
			Cast iron	3 40 01 65	3 50 01 65
2.	1	Center housing	PE conductive	1 40 10 21	1 50 10 21
3.	2	Suction/Discharge ports	Al	3 40 30 60	3 50 30 60
			AISI 316	3 40 30 52	3 50 30 52
			Cast iron	3 40 30 65	3 50 30 65
		Suction/Discharge ports-twin (Split connections)	Al	3 40 31 60	3 50 31 60
			AISI 316	3 40 31 52	3 50 31 52
4.	2	Diaphragm	TFM (PTFE)	1 40 50 05	1 50 50 05
			EPDM	1 40 50 08	1 50 50 08
			NBR	1 40 50 10	1 50 50 10
5.	4	Valve balls	PTFE	1 40 60 23	1 50 60 23
			EPDM	1 40 60 08	1 50 60 08
			NBR	1 40 60 10	1 50 60 10
			AISI 316	1 40 60 52	1 50 60 52
			Polyurethane	1 40 60 07	1 50 60 07
6.	4	Valve ball stopper	AISI 304	3 40 39 50	3 50 39 50
			AISI 316	3 40 39 52	3 50 39 52
7.	4	Sealing inlet/outlet – complete	NBR	3 40 70 10	3 50 70 10
			EPDM	3 40 70 08	3 50 70 08
			FEP/FKM	3 40 70 04	3 50 70 04
9.	8	Housing bolt	AISI 304	3 40 42 50	3 50 42 50
11.	4	Shock absorber	NR/Si37	1 25 69 06	1 40 69 06
			NR/AISI 304	1 25 69 52	1 40 69 52
12.	16	Nut with washer	AISI 304	1 40 45 59	1 50 45 59
13.	1	Air valve	PET/NBR	1 40 020 31	1 40 020 31
			PET/FKM	1 40 020 32	1 40 020 32
14.	1	Shaft	AISI 304	1 40 40 50	1 50 40 50
15.	6	O-ring	NBR	1 40 87 10	1 40 87 10
			FKM	1 40 87 09	1 40 87 09
16.	2	Center housing seal	PE	1 40 85 22	1 50 85 22
17.	1	Muffler	PE porous	1 40 99 35	1 50 99 35
			BZ	1 40 99 86	1 40 99 86
18.	1	Air adapter	PP	1 40 46 28	1 40 46 28
30.	2	O-ring for center housing seal	NBR	1 40 85 10	1 50 85 10
35.	1	Center housing complete	PE conductive	1 40 11 21	1 50 11 21
80.	2	Shaft allen pin screw	AISI 314	1 40 540 50	1 50 540 50
99.	1	Air valve key (SK4)	diverse	1 08 58 00	1 08 58 00

5.4. DM 80/850 (Aluminium version only)

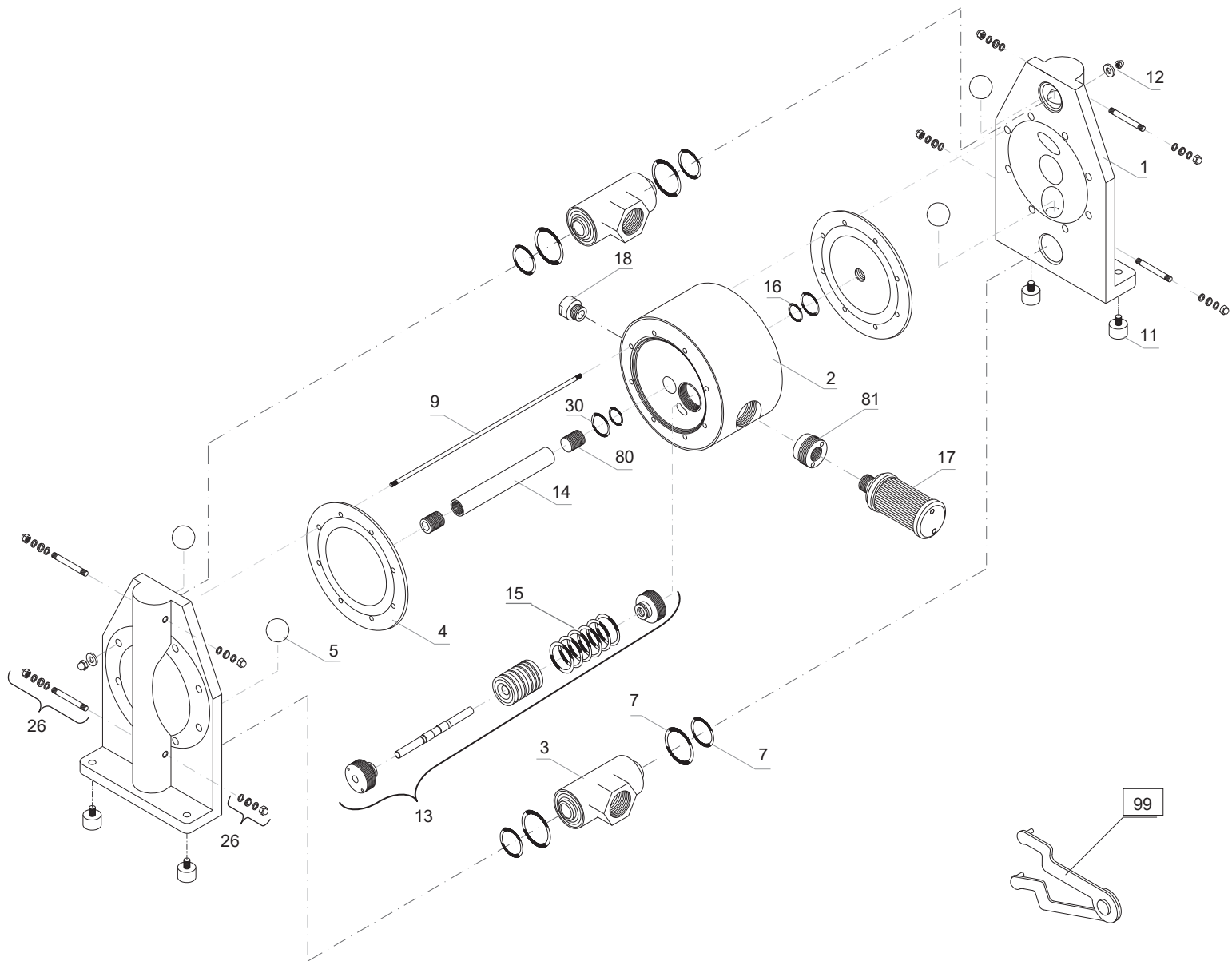

Spare parts list for DM 80/850 pump (Aluminium version only)

			MATERIAL	DM 80/850
1.	2	Pump housing	Al	3 80 01 60
2.	1	Center housing	PE conductive	1 80 10 21
3.	2	Suction/Discharge ports	Al	3 80 30 60
4.	2	Diaphragm	TFM (PTFE)	1 80 50 05
			EPDM	1 80 50 08
			NBR	1 80 50 10
5.	4	Valve balls	PTFE	1 80 60 23
			EPDM	1 80 60 08
			NBR	1 80 60 10
7.	4	Sealing inlet/outlet – cpl.	NBR	3 80 70 10
			EPDM	3 80 70 08
9.	8	Housing bolt	AISI 304	3 80 42 50
11.	4	Shock absorber	NR/St37	1 80 69 06
12.	8	Nut with washer	AISI 304	1 80 45 59
13.	1	Air valve	PET/NBR	1 80 020 31
			PET/FKM	1 80 020 32
14.	1	Shaft	AISI 304	1 80 40 50
15.	6	O-ring, air valve	NBR	1 80 080 10
			FKM	1 80 080 09
16.	2	Center housing seal	PE	1 80 85 22
17.	1	Muffler	Misc	1 80 99 00
18.	1	Air adapter	PP	1 80 46 28
26.	2	Valve stopper, cpl.	AISI 304 + PTFE	3 80 139 00
30.	2	O-ring for center housing seal	NBR	1 80 85 10
35.	1	Center housing complete	PE conductive	1 80 11 21
80.	2	Shaft allen pin screw	AISI 304	1 80 540 50
81.	1	Muffler adapter	PE conductive	1 80 299 21
99.	1	Air valve key (SK4)	diverse	1 08 58 00

6. Assembly



- ! When installing accessories prevent any foreign matter from getting into the product. Otherwise malfunction of the air-valve may follow.

7. Installation

7.1. Installing the pump

- 1) Decide where the pump is to be installed and secure a site.

Note:

- The suction lift should be kept as short as possible.
- Sufficient space around the pump for maintenance must be provided.

When fixing the pump in place, use the cushions on the pump base. The tied-down bolts should be tightened a little at a time to secure the pump.

SELF PRIMING APPLICATION

Suction lift capability may vary depending on the construction materials and application parameters. The range is from 5 meters dry to 9 meters in a primed condition (values calculated for pumping water at 20 degrees Celsius).

SUBMERGED OPERATION

All pumps may operate in full submersion. Construction materials must be compatible with surrounding liquid and the air exhaust must be placed above the liquid level.

POSITIVE SUCTION HEAD

Common as a method of drawing off the bottoms of holding tanks and clarifiers. Optimum inlet pressure should be kept at 0.2-0.3 bar.

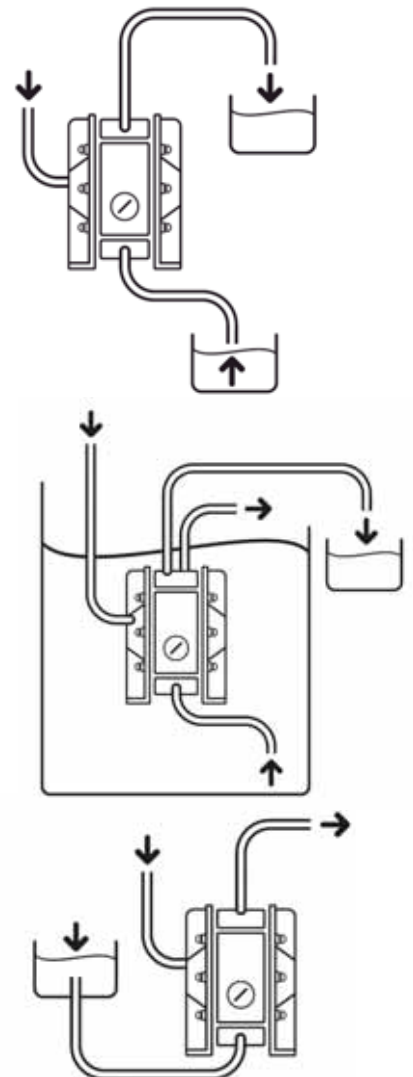



CAUTION

- ! Vibration generated by pump operation should be absorbed. Take it into consideration when mounting it.
- ! When using the pump in submerged position, follow the steps below:
 - Verify the corrosion resistance of each component of the pump. DO NOT expose the pump to any fluid for which it does not have proper corrosion resistance.
 - Exhaust should direct outside, not into the fluid in which the pump is submerged.
- ! The running pump may generate noise. Its level will depend upon conditions of use (kind of fluid being pumped, supply air pressure and discharge pressure).



WARNING

- ! The end of the hose must be equipped with a pit, a protection box, etc. at the end of the hose in case the diaphragm gets damaged and a leakage of the fluid follows.
- ! Pump exhaust should be directed to a safe place, away from people, animals and food.



CAUTION

- ! Before putting the pump into operation as well as after some hours of pumping, the housing bolts have to be fixed according to the torque data of the following schedule, as the elements of construction “settle”. Fixing the bolts is necessary as well after longer periods of stoppage, at extreme temperature variations, after transport and dismantling the pump.

Size	DM 15/25	DM 20/75	DM 25/125	DM 40/315	DM 50/565	DM 80/850
Torque values for housing bolts [Nm]:	6	8	13	17	22	25
Torque values for valve stoppers [Nm]:	5	7	7	8	8	-

7.2. Connecting the ground wire

- a) When installing the conductive pump, be sure to connect the ground wire at the specified position.
- b) Ground wires should be connected to peripheral equipment and piping as well.
- c) Use 2.0 mm² minimum ground wire.



WARNING



Ground wires must be connected to the piping and any other peripheral equipment. When operating the pump make sure it is properly grounded. Otherwise friction between the parts and abrasion caused by some fluids flowing inside the casing may generate static electricity. In addition it may cause fire or electric shock, depending on the type of fluid being pumped and the installation environment (such as gases in the air or the surrounding mixtures).

8. Connection

8.1. Connecting fluid piping

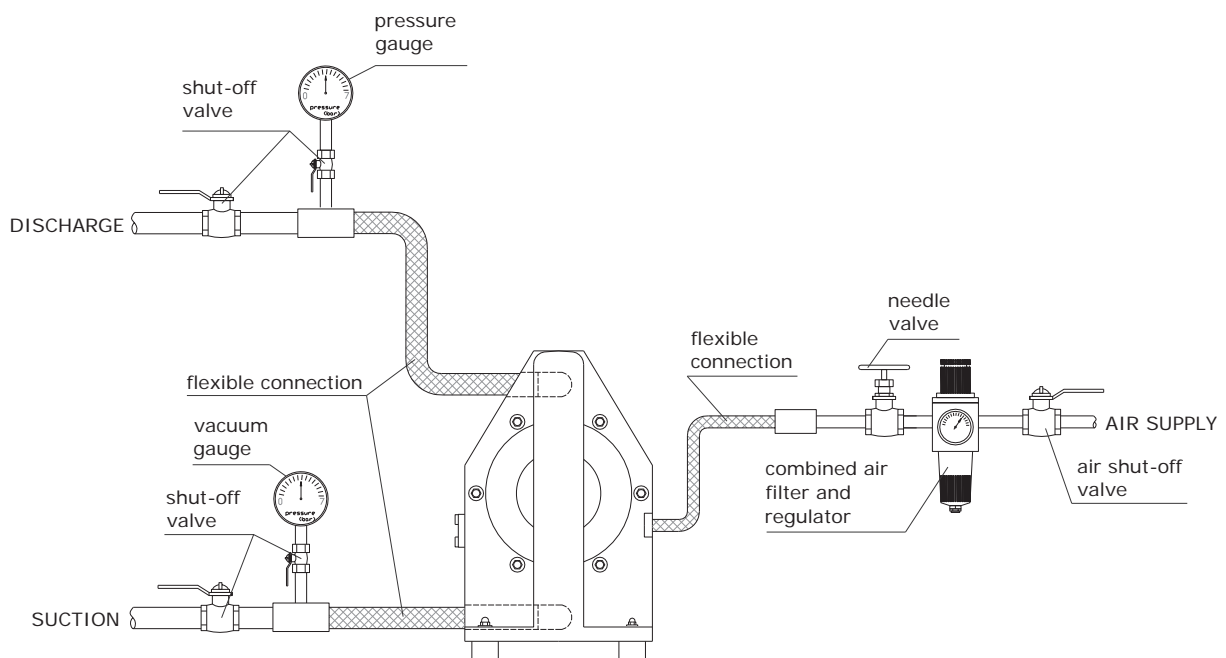

- 1) Connect a flow valve and a drain valve to the fluid discharge port of the pump.
- 2) Connect a valve for maintenance to the fluid suction intake port of the pump.
- 3) Connect a hose to the valve on the suction-port side and the valve of the discharge-port side of the pump.
- 4) Connect a hose on the suction-side intake and the discharge-port side to the respective vessels.



CAUTION

- ! A hose must be flexible to absorb pump vibration. The hose must be grounded.
- ! There must be NO external force on any connection part of the pump. Be especially careful not to have the pump support part of the weight of the hose and the piping.
- ! Use a sturdy hose that will not collapse under the strong suction of the pump. The hose must be of more than sufficient pressure rating.
- ! Use a hose of a diameter the same as or larger than the pump's ports. If the diameter of a hose is smaller, it will affect the pump's performance or cause its malfunction.
- ! Keep a vessel below the relief valve to catch any drain off.
- ! The product has been inspected using clean water at 8 bar discharge pressure.

8.2. Connecting air piping



WARNING

- ! Before starting work, make sure that the air compressor is shut off.

- 1) Connect an air valve, air filter, regulator to a hose connected to the compressor. Install items near the pump.
- 2) Connect the hose from the peripheral equipment to the air valve of the pump's supply port.

Note:

The diameter of the piping should be the same as the diameter of the pump supply port in order to supply sufficient air. Peripheral equipment with sufficient airflow should be chosen to meet the requirement of the pump air consumption. It must be installed nearest the pump unit, even using dry air. Usage and stability of air pressure must be considered.

9. Operation

9.1. Method of operation



CAUTION

- ! Before starting the pump, check that all piping is properly connected.
- ! Before starting the pump, check that **all the bolts are securely tightened.**
- ! Check that the regulator and the drain valve on the discharge side are closed and that the valve on the suction side is opened.

- 1) Start the air compressor.
- 2) Open the air valve. Using a regulator adjust the supply air pressure to within the permissible range.
- 3) Open the flow valve on the discharge side.
- 4) First, check that fluid is flowing inside the piping and is being pumped to the discharge side, and then fully open the air valve.



CAUTION

- ∅ Do NOT open the air valve suddenly.

9.2. Flow adjustment

Adjust the flow valve on the discharge side, or adjust the supply air pressure.



CAUTION

- ! The supply air pressure may initially rise during closing the flow valve. Make sure that the pressure is kept within the normal operating range.
- ! The permissible suction flow speed can vary depending upon the viscosity and specific gravity of the fluid, the suction stroke and other factors. However in case of a rapid growth of the pump speed (flow speed of fluid), cavitations will occur. This will reduce pump performance and may cause a malfunction. In order to prevent cavitations, adjust the supply air pressure and the flow.
- ! If fluid is not discharged after you start the pump, or if you hear an abnormal noise or notice any irregularity, shut down the pump immediately.

9.3. Shutdown

Close the air valve of the pump and shut off the supply air.



CAUTION

- ! The pump can be shut down with the flow valve closed while air is being supplied. However DO NOT leave the pump in this condition for many hours without supervision - there is a risk of a leak from the pump or piping, and fluid may continue flowing out of the position of leakage.
- ! When the pump is shut down while pumping slurry, particulate matter contained in the slurry will be deposited and get stuck inside the out chamber. Therefore after finishing work the pump must be purged of the remaining fluid. Otherwise when starting the pump again, the diaphragm may get damaged and the centre rod may bend.



CAUTION

- ! Keep a vessel below the relief valve for any drain off.
- ! Be careful! - Fluid under pressure will gush out the moment you open the valve.
- ! If the pump is unused for a prolonged period, purge and clean it.

10. Method of cleaning



WARNING

- ! Make sure that compressed air is not supplied to the pump BEFORE you start cleaning the pump.
- ! Make sure that the pump is not pressurized BEFORE you start cleaning the pump.

- 1) Remove the hose from the suction side of the pump.
- 2) Close the flow valve on the discharge side and open the drain valve. Then start air pressure for a while to discharge possibly much fluid remaining inside the pump.
- 3) Remove the hose from the discharge side, and attach different hoses to the suction side and the discharge side for cleaning.
- 4) Be ready with a vessel with cleaning solution, the kind appropriate for the type of fluid pumped. Next connect the suction-side and the discharge-side hoses of the pump.
- 5) Start the pump air pressure slowly, and let the cleaning solution circulate for sufficient cleaning.
- 6) Flush with clean water.
- 7) Remove the hose from the suction side of the pump, run the pump for a while to purge the pump of remaining fluid as much as possible.



CAUTION



Be extremely careful when removing piping - the fluid will gush out.



After cleaning with clean water, turn the pump upside-down to let the water flow out.

11. Daily check

Before starting pump operation, conduct the following check procedures every day. In case there appears any irregularity, do NOT start running the pump until the cause of the irregularity has been determined and corrective measures have been taken.

- a) Make sure that there is no leakage of fluid from any connection part or the pump.
- b) Make sure that there are no cracks in the pump casing or piping.
- c) Check the tightness of every bolt of the pump.
- d) Make sure that the connection parts of the piping and peripheral equipment are not loose.
- e) Make sure that any parts of the pump that are to be replaced at regular intervals have been changed.

12. Possible problems

12.1. Pump does not run

Cause	Action to take
The exhaust port (muffler) of pump is clogged with sludge.	Check and clean the exhaust port and muffler.
Air is not supplied.	Start the compressor, and open the air valve and air regulator.
The supply air pressure is low.	Check the compressor and the configuration of air piping.
Air leaks from connection parts.	Check the connection parts and tightness of bolts.
The flow valve on the discharge side is not open.	Open the flow valve on the discharge side.
The fluid piping is clogged with sludge.	Check and clean the fluid piping.
The pump is clogged with sludge.	Disassemble the casing, check and clean.

12.2. Pump runs, but fluid does not come out

Cause	Action to take
The suction lift or discharge head is long.	Confirm the piping configuration and shorten the length.
The discharge-side fluid piping (including the strainer) is clogged with sludge.	Check and clean the fluid piping.
The valve on the suction side is not open.	Open the valve on the suction side.
The pump is clogged with sludge.	Disassemble the casing, check and clean.
The balls and valve seats are worn out or damaged.	Disassemble the pump, check and replace parts.

12.3. Flow (discharge volume) decreased

Cause	Action to take
The supply air pressure is low.	Check the compressor and configuration of air piping.
Air piping or peripheral equipment is clogged with sludge.	Check and clean the air piping.
The discharge-side flow valve opens differently.	Adjust the discharge-side flow valve.
Air is taken in together with fluid.	Replenish fluid and check the configuration of the suction-side piping.
Cavitations occur.	Adjust the supply air pressure and discharge pressure, and shorten the suction lift.
Chattering occurs.	Adjust the supply air pressure and discharge pressure. Reduce inlet flow valve to adjusting liquid pressure and volume.
The fluid piping (including the strainer) is clogged with sludge.	Check and clean the fluid piping and strainer.
The exhaust port (muffler) of the pump is clogged with sludge.	Check and clean the exhaust port and muffler.
The pump is clogged with sludge.	Disassemble the casing, check and clean.

12.4. Liquid leakage from exhaust port (silencer)

Cause	Action to take
Damaged diaphragms.	Replace the diaphragms.

12.5. High air consumption during operation

Cause	Action to take
The o-rings and sleeves are worn out.	Disassemble the air-valve, check and clean. Replace parts as necessary.

12.6. Irregular noise

Cause	Action to take
The supply air pressure too high.	Adjust the supply air pressure.
The pump is clogged with sludge with particles of larger than the permissible diameter.	Disassemble the casing, check and clean.

12.7. Irregular vibration

Cause	Action to take
The supply air pressure too high.	Adjust the supply air pressure.
The sleeves are worn out.	Disassemble the air-valve, check and clean. Replace parts as necessary.
Connection parts and pump mounting are loose.	Check each connection part and tighten the bolts.

If any of the above mentioned causes do not apply to your problem, contact your dealer or our office.

13. Returning the product for servicing

If you want to return the product for servicing, copy the **Trouble-Reporting FAX Sheet**, fill it out giving the details of the problem and conditions of operation, and fax it to your dealer or our regional office.

- 1) Get an acceptance from your dealer or regional office.
- 2) Clean the pump.
- 3) Return the product in the same package as when it was first shipped from the factory.

Trouble-Reporting FAX Sheet

Your information will be most helpful in our efforts to improve our service as well as checking into causes of troubles and irregularities. We kindly request you therefore to fill out the following FAX sheet carefully and fax it to your dealer or our regional office. Thank you.

Company	Name of person in charge	
Address	Department	
	Telephone	
	Fax	e- mail
MODEL	Year of manufacturing	
Period of use	Serial No.	
Operating conditions *Indoor * Outdoor	Date of Purchase	
Frequency of operation * Continuous * Intermittent _____Hours/day/week/month	Name of Dealer _____	
	Type of fluid pumped _____	
Operating air pressure _____ bar Discharge pressure _____ bar Discharge volume _____ l/min. Suction side _____ m Suction side diameter _____ m Discharge side _____ m	Specific gravity _____ Viscosity _____ cPs Fluid temperature _____ *C/*F Slurry: *YES Density _____ wt% Particulate diameter _____ mm *NO	
Problem		
Draw a summary drawing of application (size, length of piping, and component parts)		



WARNING



It is the end-user responsibility to thoroughly wash and clean the pump to prevent any damages caused by accidental liquid leaks.



CAUTION



Be sure to maintain the transport safety by preventing any liquid leaks from the pump.

14. Main body specification

14.1. Main specification



CAUTION



Due to constant improvement or modification of our products, dimensions given can be changed without prior information. Please contact your dealer or our regional office for details.

14.2. Appearance and dimensions

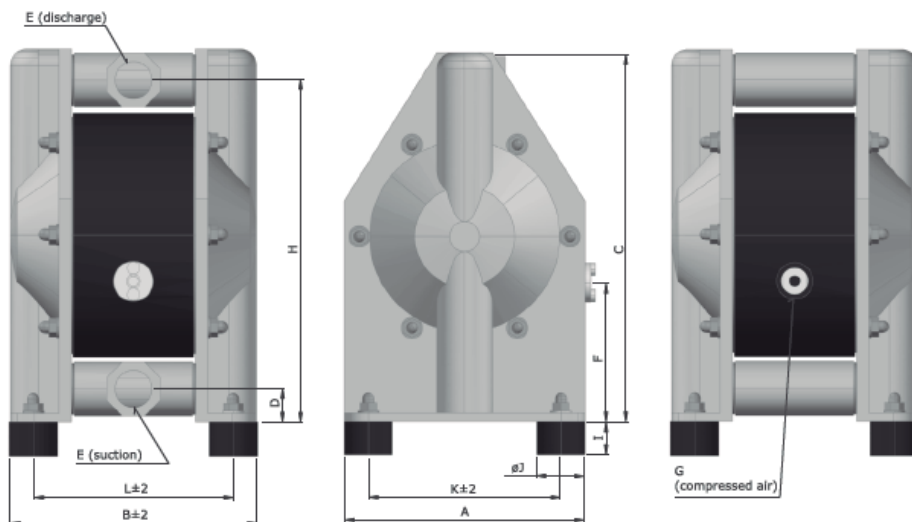

	A	B	C	D	E	F	G	H	I	ØJ	K	L
DM 15/25	104	122	166	17	G 1/2"	85	R 1/8"	153	10	15	84	98
DM 20/75	150	171	230	21	G 3/4"	84	R 1/4"	212	18	30	116	133
DM 25/125	200	202	305	27	G 1"	115	R 1/4"	280	28	40	160	164
DM 40/315	273	267	417	34	G 1 1/2"	110	R 1/2"	382	28	40	220	213
DM 50/565	352	345	546	48	G 2"	165	R 1/2"	501	30	60	282	281
DM 80/850	485	530	833	72	G 3"	364	R 3/4"	760	40	75	410	449

14.3. Technical Data

	15/25	20/75	25/125	40/315	50/565	80/850 *
Max capacity (l/min)	25	75	125	315	565	850
Max pressure (bar)	8					
Nominal port size	G 1/2"	G 3/4"	G 1"	G 1 1/2"	G 2"	G 3"
Air connection	R 1/8"	R 1/4"	R 1/4"	R 1/2"	R 1/2"	R 3/4"
Suction lift dry (mWC):	2.0	3.0	4.0	4.0	5.0	5.0
Suction lift wet (mWC)	9.0					8.0
Max diameter solids (mm)	3	4	7	10	12	15
Temperature limits - NBR, EPDM (°C)	80					
Temperature limits - PTFE (°C)	120					110
Weight – Alu (kg)	1,9	4,9	8	18	33	97
Weight – AISI 316 (kg)	-	9,5	14,0	31,0	70,0	-
Weight – Cast Iron (kg)	3,3	9,5	16,0	36,0	75,0	-
Material of pump housing	Aluminium, Aluminium coated with PTFE, AISI 316, Cast Iron					Aluminium
Diaphragm options	NBR, EPDM or TFM/PTFE					
Valve balls	NBR, EPDM, PTFE, AISI 316, PU					NBR, EPDM, PTFE
O-rings	NBR, EPDM or FEP/FKM					

The above figures represent EPDM-fitted pump capabilities.
It can vary for PTFE-fitted diaphragm.

* Aluminium pump only

14.4. Pump code

<p>DM 15/25 ANT – DM1</p>	<p>DM1 - Optional equipment:</p>
<p>DM - Dellmeco Pump</p> <p>15 - Port dimension, DN</p> <p>25 - Max capacity l/min at 8 bar</p>	<p>BC1 – Barrier chamber with sensors (NAMUR)</p> <p>BC2 – Barrier chamber as BC1 with controllers</p> <p>BC3 – Barrier chamber as BC2, ATEX</p> <p>DM1 – Diaphragm monitoring, NAMUR – ATEX</p> <p>DM2 – Diaphragm monitoring with controller</p>
<p>A - Housing material:</p> <p>A - Aluminium</p> <p>B - Aluminium coated with PTFE</p> <p>C - Cast iron</p> <p>S - AISI 316</p>	<p>SC1 – Stroke sensor, ATEX</p> <p>SC2 – SC1 plus stroke counter</p> <p>SC3 – SC1 plus stroke counter – ATEX</p> <p>SC5 – Stroke counting pneumatical with pressure transmitter</p> <p>SC6 – SC5 plus stroke counter</p> <p>F7 – Flange Connection PN10 DIN 2576</p> <p>F8 – Flange Connection ANSI 150 RF-SO</p> <p>F9 – Flange Connection PN16 DIN 2277/2278</p>
<p>N - Diaphragm material:</p> <p>E - EPDM</p> <p>N - NBR</p> <p>T - TFM/PTFE</p>	<p>AF1, AF2 - Air filter, regulator, valve, nipple, connector</p> <p>BF1 – Back flushing system, hand operated, EPDM seals (Alu & CI pumps)</p> <p>BF2 – Back flushing system, hand operated, PTFE seals (AISI 316 pumps)</p> <p>BF3 – Back flushing system, hand operated, FKM seals (Alu & CI pumps)</p>
<p>T - Material ball valve:</p> <p>E - EPDM</p> <p>N - NBR</p> <p>S - AISI 316</p> <p>T - PTFE</p> <p>U - Polyurethane</p>	<p>D – Drum pump</p> <p>HP – High pressure</p> <p>HJ – Heating Jacket (AISI 316 pumps only)</p> <p>MV – Pump with solenoid valve</p> <p>P – Powder pump (Aluminium pumps only)</p> <p>S – Sleeve with split connections</p> <p>X – ATEX</p> <p>CLEAN – The clean package to meet enlarged purity requirements for special pump applications (AISI 316 pumps only)</p>

14.5. Performance curves

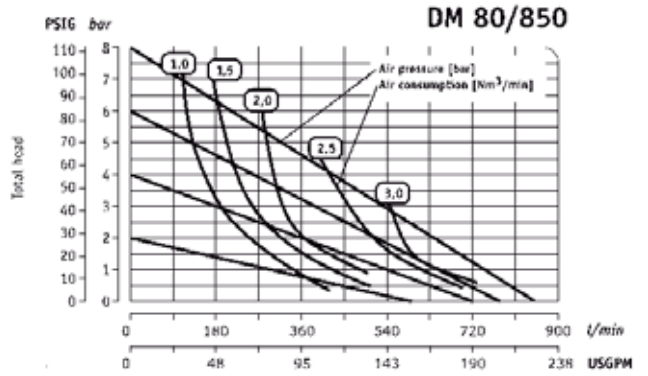
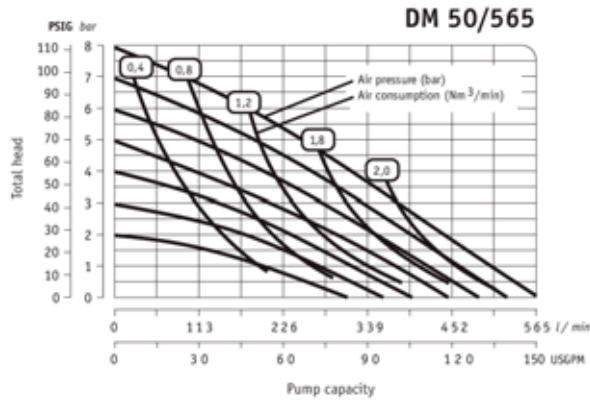
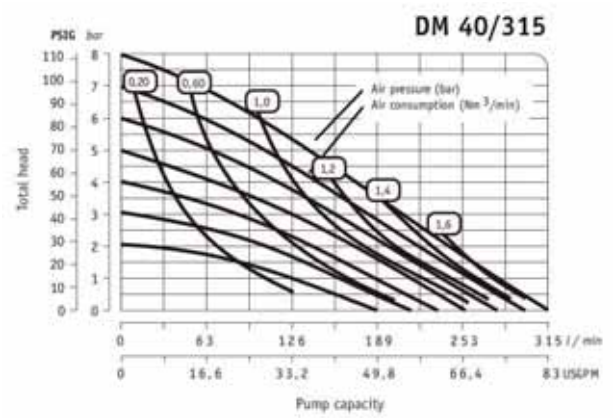
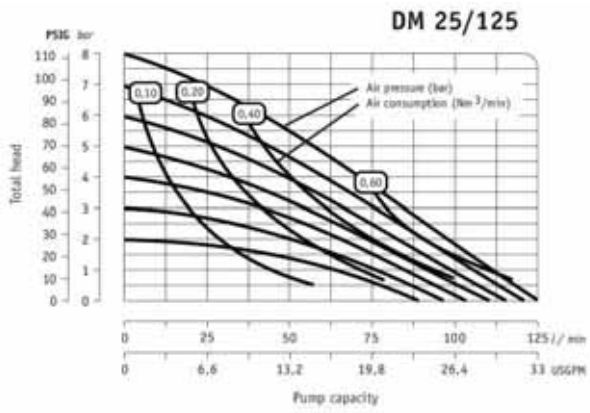
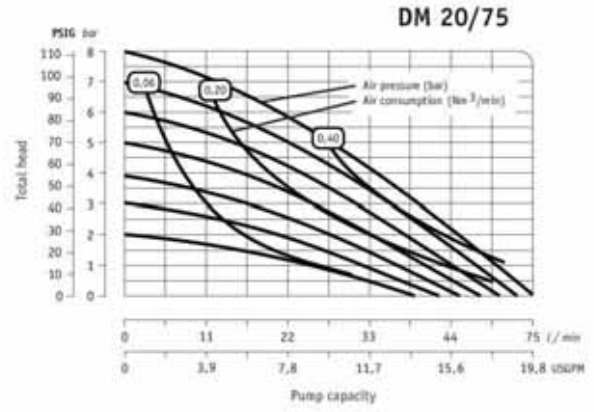
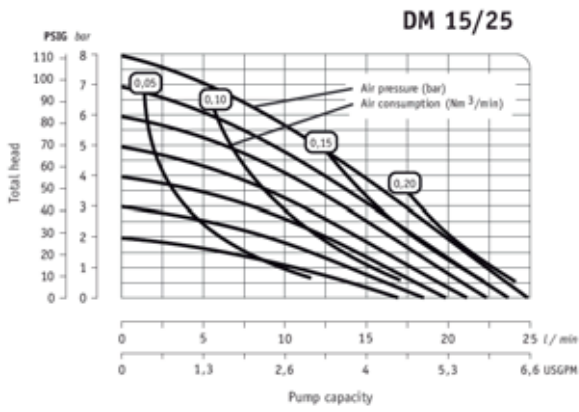

15. Dellmeeco Active Pulsation Dampers for Metal Pumps

15.1. Main specification

DELLMECO active pulsation dampers represent the latest generation of active pulsation dampers. They are specially designed to be used along with DELLMECO pneumatic double diaphragm pumps of the metal range. A general aspect to be considered is, that a pulsation damper decreases the total capacity of the system depending on the point of operation.

Before putting a DELLMECO pulsation damper into operation, make sure, that the materials of construction are resistant to the chemical to be pumped. To check this, the exact damper code is required. This code, as well as the serial number, can be found in identification plates on the damper itself.

Example of the damper type code:

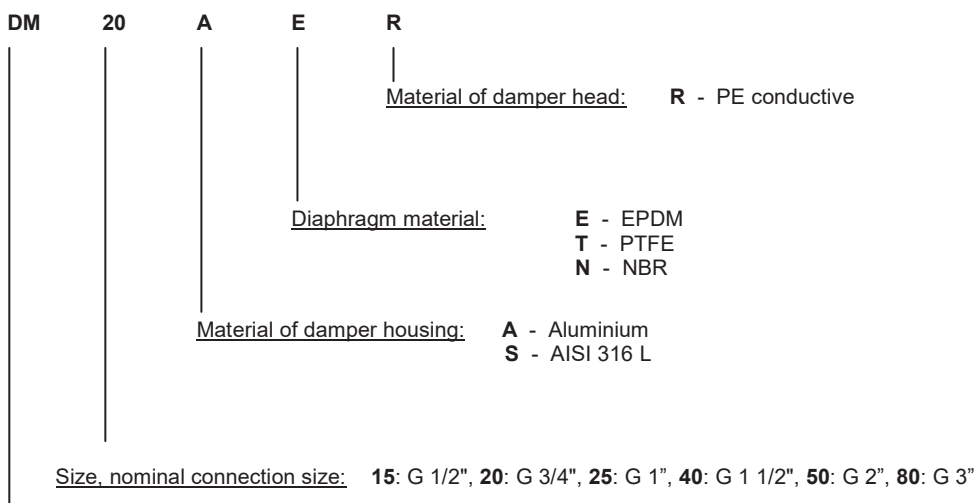

DELLMECO pulsation damper.

Air supply connection: DM 15-25: R 1/8", DM 40-50: R 1/4", DM 80: R 1/2"

Max. operating pressure: 8 bar

For inflammable liquids as well as for applications in explosion protected areas, only dampers made of PE conductive (code R) may be used. It is necessary to ground the damper separately, as the damper is not connected to the pump, which is conductive and has to be grounded itself.

Before connecting the pump, take the yellow blind plugs out of air inlet which is located on the top of the damper head [41]. For correct operation, the damper absolutely needs an air-supply of its own, which has to be taken from the air-supply of the pump. Pump and pulsation damper have to be connected to the same air pressure. No stop or regulating valve may be placed between pump and damper. The driving air has to be oil-free, dry and clean. Together with the pump an empty damper has to be driven slowly. The dampers are self-regulating for all changing operating conditions.

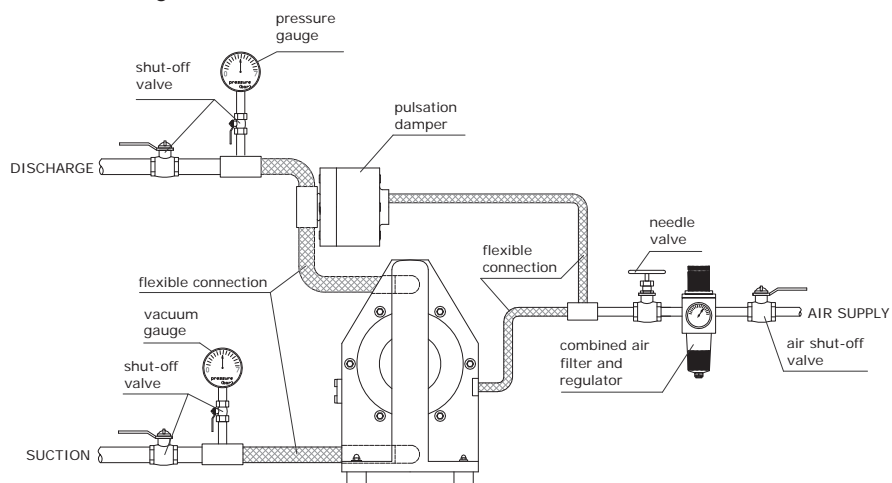



CAUTION

- ! Before putting the pulsation damper into operation as well as after some hours of operating, the housing bolts [42] have to be tightened carefully, as the elements of construction tend to "settle". Fixing the bolts is necessary as well after longer periods of stoppage, at extreme temperature variations, transport and after dismantling.
- ! Pressure tests of the plant the pump and the damper are included and may only be carried out with the aggregate (pump and damper) disconnected from the pressure on both ports or by using the pressure the aggregate develops while operating. The load of a pressure in the plant may damage the pump and the pulsation damper.
- ! Before starting to disassemble the pump, take care that pump and damper have been emptied and rinsed. Further, both have to be cut off from any energy on the air and product side. If pump and damper is being deported from the plant, a reference about the delivered liquid has to be attached.
- ! Please respect the relevant additional security advices, if the pump and the damper have been used for aggressive, dangerous or toxic liquids.
- ! Before putting the pump and the damper back into operation, the tightness of both has to be checked.

Disassembly instructions

Unscrew housing bolts [42] carefully. After that, all parts can be removed. Screw the diaphragm [40] off the actuator shaft [39]. A re-assembly of used piston rings [37] is impossible; they have to be replaced including the O-rings underneath. To assemble new piston rings [37] carefully shape them like kidneys with locking ring pliers and insert the rings into the grooves; completely press the rings into the grooves smoothly using some round tool.

Spare part list, pulsation damper series

Damper size				DM 15	DM 20	DM 25	DM 40	DM 50	DM 80
Pos.	Quantity	Description	Material	Part no.	Part no.	Part no.	Part no.	Part no.	Part no.
36	1	Damper housing	Al	8 15 01 60	8 20 01 60	8 25 01 60	8 40 01 60	8 50 01 60	8 80 01 60
			AISI 316	-	8 20 01 52	8 25 01 52	8 40 01 52	8 50 01 52	-
37	3	Piston ring	PE	1 08 90 22	1 08 90 22	1 15 85 22	1 25 85 22	1 40 85 22	1 50 85 22
38	3	O-ring	NBR	1 08 82 10	1 08 82 10	1 15 85 10	1 25 85 10	1 40 85 10	1 50 85 10
39	1	Actuator shaft	PET / AISI 304*	8 10 40 30	8 15 40 30	8 25 40 30	8 40 40 50*	8 50 40 50*	8 50 40 50
40	1	Diaphragm	EPDM	-	1 10 50 08	1 15 50 08	1 25 50 08	1 40 50 08	1 50 50 08
			TFM / PTFE	1 08 50 05	1 10 50 05	1 15 50 05	1 25 50 05	1 40 50 05	1 50 50 05
			NBR	-	1 10 50 10	1 15 50 10	1 25 50 10	1 40 50 10	1 50 50 10
			EPDM/TFM/PFA	-	1 10 50 00	1 15 50 00	-	-	-
41	1	Damper head	PE conductive	8 10 203 21	8 15 203 21	8 25 203 21	8 40 203 21	8 50 203 21	8 80 203 21
42	4 / 6** / 8***	Housing bolt	AISI 304	8 10 642 50	8 15 642 50	8 25 642 50**	8 40 642 50**	8 50 642 50***	8 80 642 50***
43	8 / 12** / 16***	Nut with washer (covered)	AISI 304	1 10 145 50	1 15 145 50	1 25 145 50**	1 40 145 50**	1 50 145 50***	1 80 145 50***
44	1	Muffler	PE	8 10 99 20	8 15 99 20	8 25 99 20	8 40 99 20	8 50 99 20	8 80 99 20
45	1	Damper housing O-ring	FEP/FKM	8 10 79 04	2 15 70 04	3 25 70 04	8 40 79 04	2 40 78 04	8 80 79 04
			EPDM	8 10 79 08	2 15 70 08	3 25 70 08	8 40 79 08	2 40 78 08	8 80 79 08
46	8 / 12** / 16***	Damper plug set	PE	2 08 058 20	2 15 058 20	8 15 058 20**	8 25 058 20**	2 50 058 20***	2 80 058 20***

PULSATION DAMPER – Exploded view

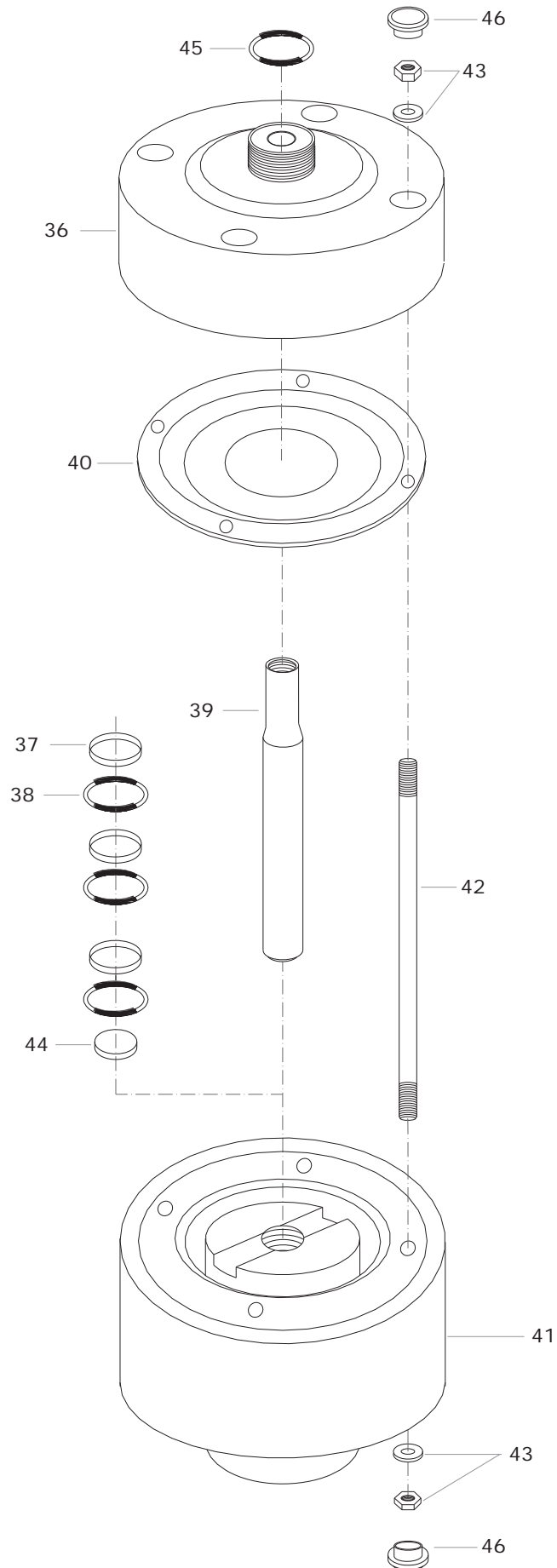

15.2. Appearance and dimensions

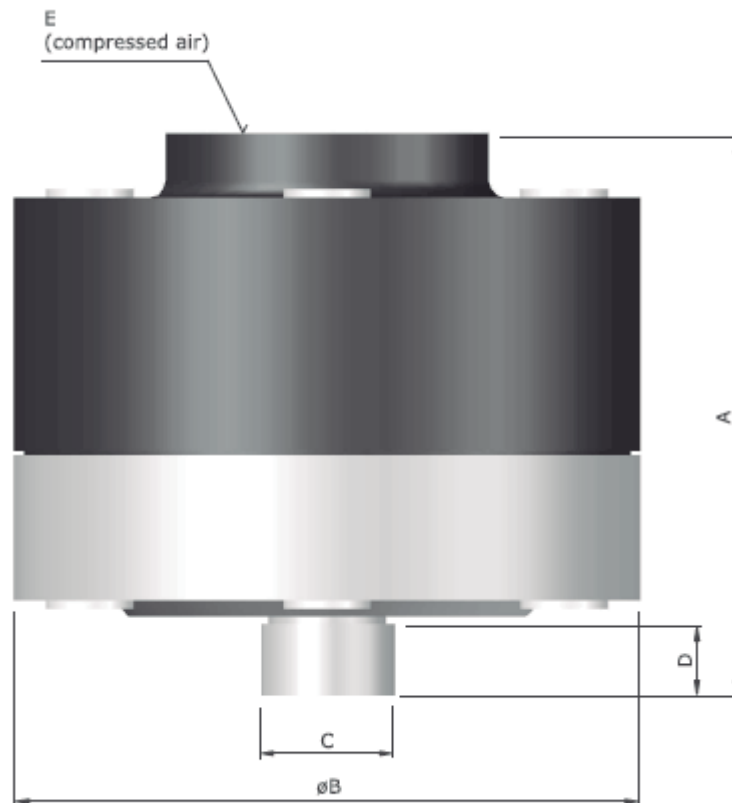

Type	DM 15	DM 20		DM 25		DM 40		DM 50		DM 80
Damper housing	Alu	Alu	AISI 316 L	Alu	AISI 316 L	Alu	AISI 316 L	Alu	AISI 316 L	Alu
A [mm]	98	98	141	138	141	170	171	216	230	287
B [mm]	110	110	156	156	156	204	204	273	273	360
C [in.]	G 1/2"	G 3/4"	G 3/4"	G 1"	G 1"	G 1 1/2"	G 1 1/2"	G 2"	G 2"	G 3"
D [mm]	13	13	18	18	18	17	20	30	30	32
E [in.]	R1/8"	R1/8"	R1/8"	R1/8"	R1/8"	R1/4"	R1/4"	R1/4"	R1/4"	R 1/2"

16. Optional Equipment

Additional information to the operating and installation instructions ought to be studied before installing the pump

For special requirements DELLMECO pneumatic diaphragm pumps of the Metal Series can be furnished with several optional equipment. The pump code informs, which of these are included in the pump.

16.1. Barrier Chamber System (option code BC1, BC2, BC3)

To comply with high safety standards, the barrier system replaces the standard diaphragm [4] by a tandem arrangement of two diaphragms [4, 59] and two barrier chambers [52, 53] of conductive PE filled with a non-conductive liquid (de-ionized water) in between. To ensure the correct operation of the pump, the barrier chambers [52, 53] have to be filled completely. Therefore, they are monitored by liquid sensors [60]. After loosening the plug [57] the barrier liquid can be refilled. In case a diaphragm breaks, the conductivity of the barrier liquid rises which is registered by the conductivity sensors [56]. The minimum conductivity of 22 μ S covers a wide range of media. Otherwise, a conductive barrier liquid can be filled into the chamber, so that the liquid emerging in case of a diaphragm rupture causes a decrease in conductivity to be registered. After using for some time the de-ionized water can be polluted with germs. In this case the water needs to be replaced.

The barrier system is available in three variations:

- BC 1 Barrier system with sensors, standard
- BC 2 Barrier system complete with sensors and controllers
- BC 3 Barrier system complete with sensors and controllers for explosion-proof zone

The four conductivity sensors [56] are pre-installed. After connection of the wire (wire not part of supply) only the PG-threads have to be screwed onto. Both liquid sensors [60] are installed completely.

The sensors can either be connected to an existing controller (code BC1) or to the controller included (code BC2 / BC3). The wiring diagram and technical data can be found on the controller itself. For further details, please refer to the data delivered by the manufacturers of the components. The controllers have to be installed in a suitable cabinet.

Spare part list, Barrier Chamber System

				Pump size:	DM 15	DM 20	DM 25	DM 40	DM 50
Code	Position	Quantity	Description	Material	Part no.	Part no.	Part no.	Part no.	Part no.
BC 1	47	2	Suction / Discharge Ports	Al	3 15 32 60	3 20 32 60	3 25 32 60	3 40 32 60	3 50 32 60
				AISI 316	3 15 32 52 ⁽¹⁾	3 20 32 52	3 25 32 52	3 40 32 52	3 50 32 52
	48	4 / 6* / 8**	Barrier chamber housing bolt	AISI 304	9 15 042 50	9 20 042 50*	9 25 042 50*	9 40 042 50**	9 50 042 50**
	49	1	Barrier chamber set screw shaft	AISI 304	1 10 41 50	1 15 41 50	1 25 41 50	1 40 41 50	1 50 41 50
	50	2	Spacer	PET	1 10 63 30	1 15 63 30	1 25 63 30	-	-
	51	2	Spacer bolt	AISI 304	1 10 43 50	-	-	-	-
	52	1	Left barrier chamber	PE conductive	2 10 202 21	2 15 202 21	2 25 202 21	2 40 202 21	2 50 202 21
	53	1	Right barrier chamber	PE conductive	2 10 302 21	2 15 302 21	2 25 302 21	2 40 302 21	2 50 302 21
	54	2	Sensor sleeve	PE	2 15 62 20	2 15 62 20	2 15 62 20	2 15 62 20	2 15 62 20
	55	2	Sensor sleeve o-ring	FKM	1 08 82 09	1 08 82 09	1 08 82 09	1 08 82 09	1 08 82 09
	56	4	Conductivity sensor	diverse	9 15 15 00	9 15 15 00	9 15 15 00	9 15 15 00	9 15 15 00
	57	2	Plug	PA	1 15 48 40	1 15 48 40	1 15 48 40	1 15 48 40	1 15 48 40
	58	2	Plug o-ring	FKM	1 15 74 09	1 15 74 09	1 15 74 09	1 15 74 09	1 15 74 09
	59	2	Inner diaphragm	EPDM	1 10 51 08	1 15 51 08	1 25 51 08	1 40 51 08	1 50 51 08
60	2	NAMUR liquid sensor	diverse	9 15 12 00	9 15 12 00	9 15 12 00	9 15 12 00	9 15 12 00	
61	2	Liquid sensor o-ring	FKM	1 15 75 09	1 15 75 09	1 15 75 09	1 15 75 09	1 15 75 09	
BC 2	as BC1, but additionally contains:								
	-	1	Controller	diverse	9 15 14 00	9 15 14 00	9 15 14 00	9 15 14 00	9 15 14 00
	-	1	Conductivity measuring trans.	diverse	9 15 13 00	9 15 13 00	9 15 13 00	9 15 13 00	9 15 13 00
BC 3	as BC2, but for EExia II C:								
	-	1	Controller	diverse	9 15 14 00	9 15 14 00	9 15 14 00	9 15 14 00	9 15 14 00
	-	1	Conductivity measuring trans.	diverse	9 15 08 00	9 15 08 00	9 15 08 00	9 15 08 00	9 15 08 00

(1) – Cast Iron pumps with BC option

Exploded view, Barrier Chamber System for DM 15

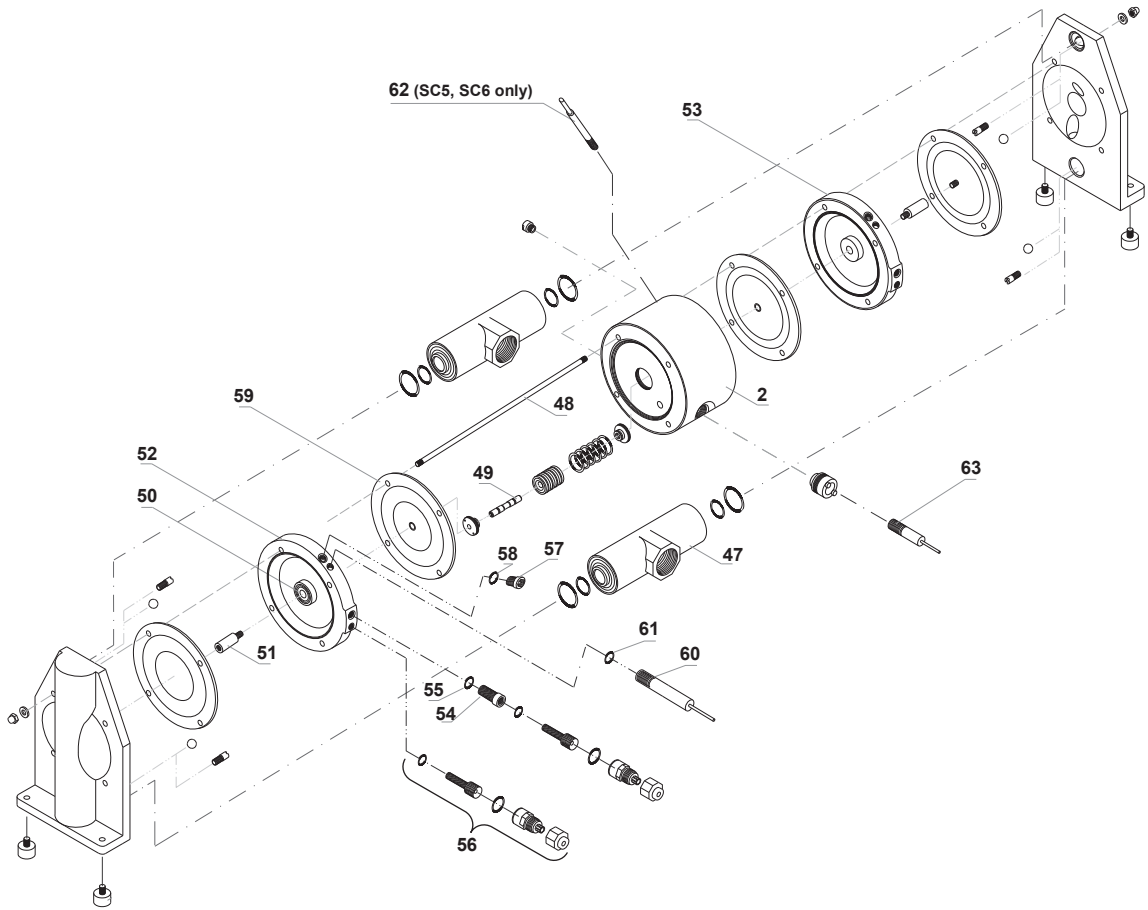

Exploded view, Barrier Chamber System for DM 20, 25, 40, 50

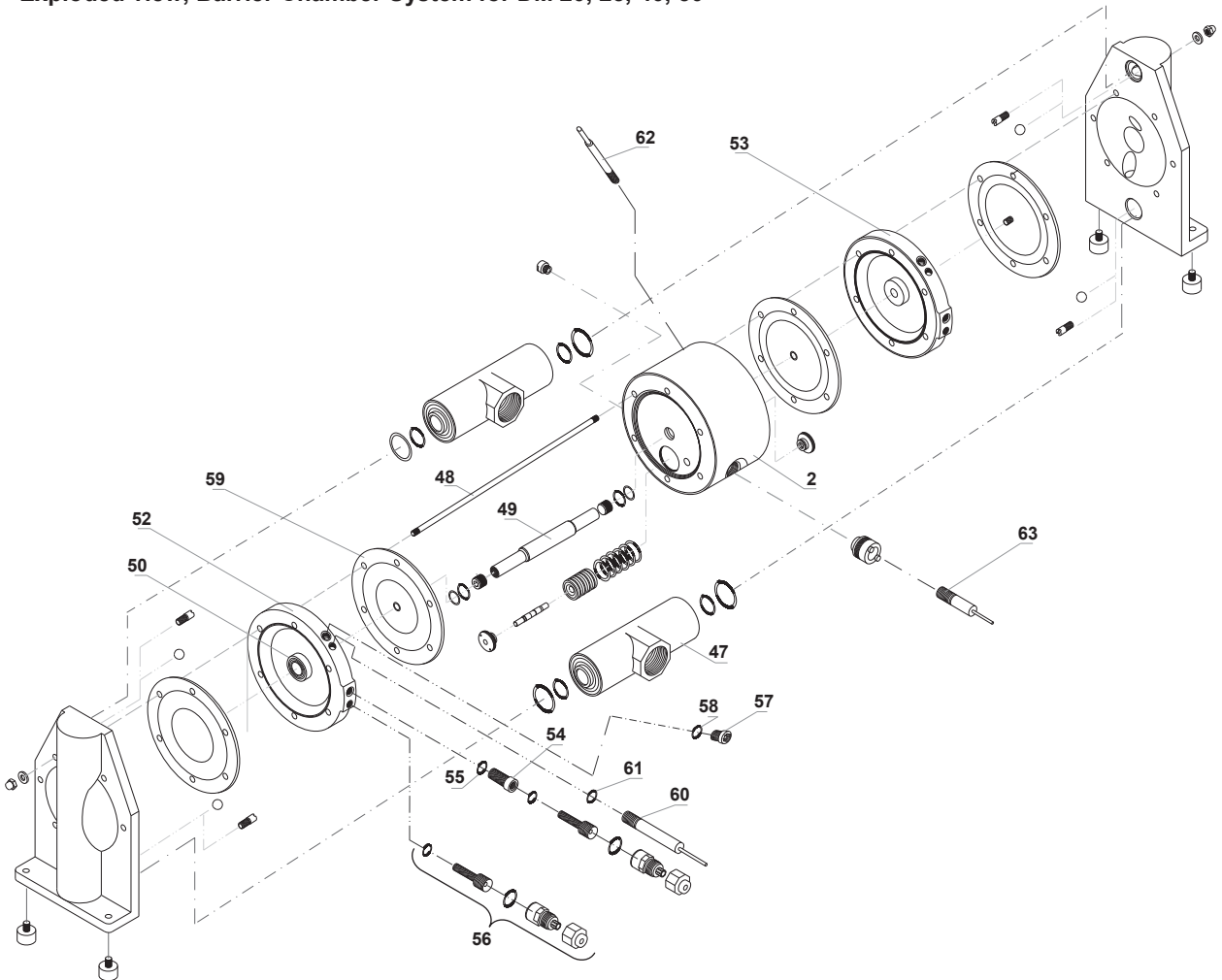

Appearance and dimensions (pump with Barrier Chamber System)

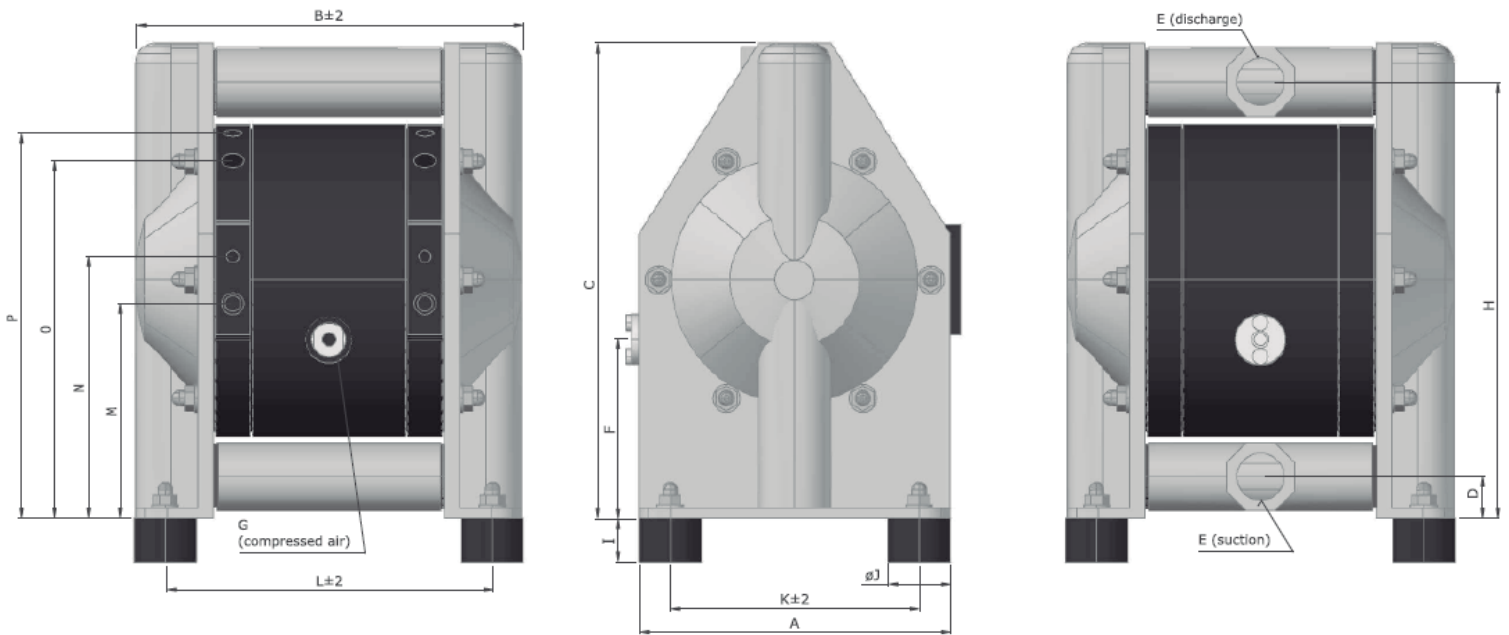

	A	B	C	D	E	F	G	H	I	ØJ	K	L	M	N	O	P
DM 15/25	104	167	166	17	G 1/2"	85	R 1/8"	153	10	15	84	143	61	84	128	146
DM 20/75	150	217	230	21	G 3/4"	84	R 1/4"	212	7	9	116	179	86	111	191	209
DM 25/125	200	252	305	27	G 1"	115	R 1/4"	280	7	9	160	214	146	176	250	270
DM 40/315	273	315	417	34	G 1 1/2"	110	R 1/2"	382	11	9	220	261	204	229	349	369
DM 50/565	352	393	546	48	G 2"	165	R 1/2"	501	10	9	282	329	253	278	443	463

16.2. Stroke Counting (option code SC1, SC2, SC3, SC5, SC6)

a) Code SC1, SC2, SC3

A sensor is installed in the central pump housing to count the strokes. The diaphragm movement is scanned without contact by this sensor: a safe form of monitoring totally independent of external influences and the pump's mode of operation. The issued sensor pulses can be output to existing detectors or to a stroke counter, which can also be supplied on request. When the preset value is reached, the stroke counter outputs a signal which can then be processed further, for instance in order to shut down the pump via a solenoid valve.

The stroke counting system is available in three variations:

- SC 1 Stroke sensor (NAMUR), also for explosion-proof zone
- SC 2 Stroke counting system complete with sensor and stroke counter
- SC 3 Stroke counting system complete with sensor, stroke counter and controller for explosion-proof zone

In case only the sensor is included (code SC1), it has to be connected to an existing controller with NAMUR inlet. For applications an explosion-proof device is required for (code SC3) the intrinsically safe controller has to be installed between the sensor and the counter. The wiring diagram and technical data can be found on the electric units themselves. For further details, please refer to the data delivered by the manufacturers of the components. The controllers have to be installed in a suitable cabinet.

b) Code SC5, SC6

Differently from the optional equipment codes SC1-SC3, the strokes of the pump are registered pneumatically on the codes SC5 and SC6. The pressure transmitter registers the changes in pressure within the air chamber behind one of the diaphragms and it converts the pneumatic impulse into an electrical signal.

The pneumatic stroke counting system is available in two types:

- **SC 5** consist of:
 - pressure transmitter 1-10 bar
 - socket with cable 2,5 m
 - adaptor elbow NPT ¼ (or adaptor straight M5 for DM 15/25 pumps only)
 - hose DN 4/6; 2,5m
- **SC 6** consist of:
 - SC 5 plus stroke counter

For assembly, screw the adaptor straight into the pressure transmitter (connection P1) and adaptor elbow into the additional air connection of the pump (it is possible that the adaptors are already installed). The position of the air inlet varies depending in the pump type and the pump size (see comments below). Link up both adaptors with the hose. Connect the socket to the electrical connection plug of the pressure transmitter and the cable to existing registering devices (Code SC5) resp. to the enclosed stroke counter (Code SC6). Technical data, connection schemes and further details can be found in the technical documentation delivered by the manufacturers of the pressure transmitter and the stroke counter.



CAUTION



The pneumatic stroke counting system requires a minimum air pressure of 1.5 bar for optimal function.

The air inlet for the pneumatic stroke counting system must not be confused with the actual air inlet of the pump. Therefore, you will find some advises adapted to the pump type and the pump size.

Spare part list, Stroke Counting

				Pump size:					
Code	Position	Quantity	Description	Material	DM 15	DM 20	DM 25	DM 40	DM 50
				Material	Part no.	Part no.	Part no.	Part no.	Part no.
SC1	2	1	Center housing for sensor	PE conductive	-	1 15 09 21	1 25 09 21	1 40 09 21	1 50 09 21
	62	1	Stroke sensor	diverse	-	9 15 16 00	9 15 16 00	9 15 16 00	9 15 16 00
SC2	as SC 1 but additionally contains:								
	-	1	Clamp amplifier	diverse	-	9 15 18 00	9 15 18 00	9 15 18 00	9 15 18 00
	-	1	Stroke counter	diverse	-	9 15 17 00	9 15 17 00	9 15 17 00	9 15 17 00
SC3	as SC 1 but additionally contains:								
	-	1	Controller	diverse	-	9 15 14 00	9 15 14 00	9 15 14 00	9 15 14 00
	-	1	Stroke counter	diverse	-	9 15 17 00	9 15 17 00	9 15 17 00	9 15 17 00
SC5	-	1	Center housing with additional air connection R 1/4"	PE conductive	1 10 109 21	1 15 109 21	1 25 109 21	1 40 109 21	1 50 109 21
	-	1	Adaptor elbow	PP	-	1 08 092 28	1 08 092 28	1 08 092 28	1 08 092 28
	-	1	Adaptor straight	PP	1 08 192 28	-	-	-	-
	-	1	Hose 2,5 m	PE	1 08 292 20	1 08 292 20	1 08 292 20	1 08 292 20	1 08 292 20
	-	1	Pressure transmitter	diverse	9 08 28 00	9 08 28 00	9 08 28 00	9 08 28 00	9 08 28 00
	-	1	Socket with cable 2,5 m	diverse	1 08 392 00	1 08 392 00	1 08 392 00	1 08 392 00	1 08 392 00
SC6	as SC 5 but additionally contains:								
	-	1	Stroke counter	diverse	9 15 17 00	9 15 17 00	9 15 17 00	9 15 17 00	9 15 17 00

16.3. Diaphragm Monitoring (option code DM1, DM2)

Although DELLMECO diaphragms with integrated metal core are designed for an optimum service life, the diaphragm remains a wear part. If it breaks, liquid can leak into the center housing and possibly emerge through the muffler. This can be prevented simply and effectively with the DELLMECO diaphragm monitoring.

A capacitive diaphragm sensor [63] is mounted in the muffler [17] of the pump, which registers any liquid approaching the sensor, no matter whether the liquid is conductive or not. Hence, a fast reaction to a damage of a diaphragm becomes possible. In case of humid surrounding air a false alert may occur despite operating the pump with dried compressed air.

The diaphragm monitoring system is available in two variations:

- DM 1 Diaphragm sensor (NAMUR), also for explosion-proof area
- DM 2 Diaphragm monitoring system complete with sensor and controller

The diaphragm sensor can either be connected to an existing controller with NAMUR inlet (code DM1) or to the controller included (code DM2). The wiring diagram and technical data can be found on the controller itself. For further details, please refer to the data delivered by the manufacturers of the components. The controllers have to be installed in a suitable cabinet.

Spare part list, Diaphragm Monitoring

				Pump size	DM 15	DM 20	DM 25	DM 40	DM 50
Code	Pos.	Quantity	Description	Material	Part no.	Part no.	Part no.	Part no.	Part no.
DM 1	63	1	Diaphragm sensor, NAMUR	diverse	9 15 19 00	9 15 19 00	9 15 19 00	9 15 19 00	9 15 19 00
DM 2	63	1	Diaphragm sensor, NAMUR	diverse	9 15 19 00	9 15 19 00	9 15 19 00	9 15 19 00	9 15 19 00
	-	1	Controller	diverse	9 15 14 00	9 15 14 00	9 15 14 00	9 15 14 00	9 15 14 00

16.4. Flange Connections (option code F4, F7, F8, F9)

This version offers the possibility to use flange connectors according to: JIS 5K (F4), PN10 DIN 2576 (F7), ANSI 150 RF-SO (F8), or PN16 DIN 2277/2278 (F9).

				Pump size:	DM 15	DM 25	DM 40	DM 50
Code	Pos.	Quantity	Description	Material	Part no.	Part no.	Part no.	Part no.
F4	-	2	Flange pipe	AISI 316	3 15 125 52	3 25 125 52	3 40 125 52	3 50 125 52
	-	2	JIS 5K flange collar	PE	2 15 525 20	2 25 525 20	2 40 525 20	2 50 525 20
				PE conductive	2 15 525 21	2 25 525 21	2 40 525 21	2 50 525 21
as F4, but:								
F7	-	2	PN10/DIN 2576 flange collar	PE	2 15 225 20	2 25 225 20	2 40 225 20	2 50 225 20
				PE conductive	2 15 225 21	2 25 225 21	2 40 225 21	2 50 225 21
				as F4, but:				
F8	-	2	ANSI 150 RF-SO flange collar	PE	2 15 325 20	2 25 325 20	2 40 325 20	2 50 325 20
				PE conductive	2 15 325 21	2 25 325 21	2 40 325 21	2 50 325 21
				as F4, but:				
F9	-	2	PN16 DIN 2277/2278 flange collar	PE	2 15 425 20	2 25 425 20	2 40 425 20	2 50 425 20
				PE conductive	2 15 425 21	2 25 425 21	2 40 425 21	2 50 425 21
				as F4, but:				

16.5. Sleeve with Split Connections (option code S)

The pumps of the Metal Series can be converted from a double-acting air-driven diaphragm pump into two separated single-acting ones. The standard sleeve with one suction and one discharge connection is exchanged for a sleeve with split connections, so with separate suction and discharge connections for both pump chambers. By separation in two pump halves with the same drive there are two liquid streams in 1:1 ratio.

The chart below shows configuration of the split connections. The nominal port size may be different from standard sleeve (e.g. for DM 25 is 3/4 ").

Spare part list, Split Connections

Pump size					DM 15	DM 20	DM 25	DM 40	DM 50
Code	Position	Quantity	Description	Material	Part no.	Part no.	Part no.	Part no.	Part no.
S	64	2	Sleeve with split connections	Al	3 15 31 60	3 20 31 60	3 25 31 60	3 40 31 60	3 50 31 60
				AISI 316	3 15 31 52 ⁽²⁾	3 20 31 52	3 25 31 52	3 40 31 52	3 50 31 52
Nominal port size					G 3/8"	G 1/2"	G 3/4"	G 1 1/4"	G 2"

(2) – Cast Iron pumps with S (Split Connections) option

16.6. Back Flushing System (option code BF1, BF2, BF3)

A pump equipped with the back flushing system can be emptied along with an inclining discharge line while being installed within the plant. It consists of a ball-lift system in the side housings which can be activated by manual valves.

Open the manual valves by turning blocking pins [68] to the left (approx. 90°). The pump should be kept in operation meanwhile. Slow down the pump slowly and finally stop it. The pump is drained entirely on the suction side.

The side housing o-rings are made from EPDM (BF1 – Aluminium and Cast Iron Pumps), PTFE (BF2 – AISI 316 Pumps) or FKM (BF3 - Aluminium and Cast Iron Pumps).

Appearance of Back Flushing System

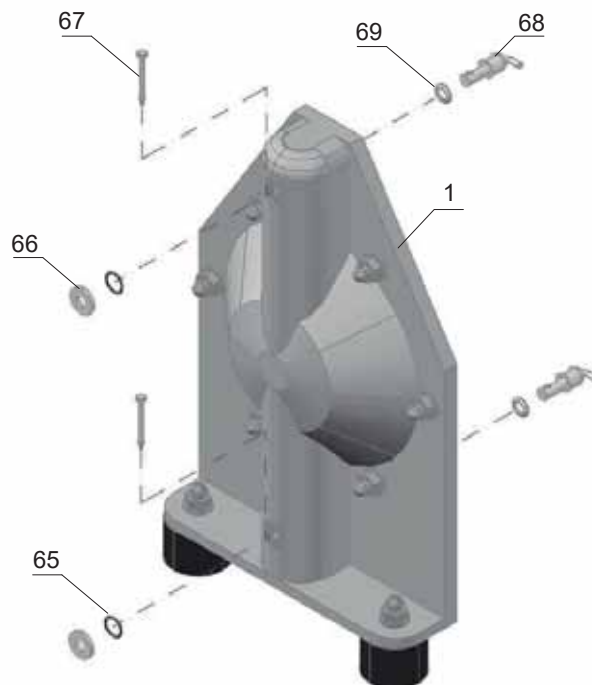

Spare part list, Back Flushing System (hand operated only)

Code:	Item	Pcs.	Description	Material	DM 20	DM 25	DM 40	DM 50	
					Part no.	Part no.	Part no.	Part no.	
BF1	1	1	Pump housing left for BF system	Aluminium	3 20 001 60	3 25 001 60	3 40 001 60	3 50 001 60	
				Cast Iron	3 20 001 65	3 25 001 65	3 40 001 65	3 50 001 65	
		1	Pump housing right for BF system	Aluminium	3 20 301 60	3 25 301 60	3 40 301 60	3 50 301 60	
				Cast Iron	3 20 301 65	3 25 301 65	3 40 301 65	3 50 301 65	
		65	8	O-ring for pump housing	EPDM	3 20 372 08	3 25 372 08	3 40 372 08	3 50 372 08
		66	2	Washer	AISI 316	3 20 157 52	3 25 157 52	3 40 157 52	3 50 157 52
		67	4	Blocking pin	AISI 316	3 20 342 52	3 25 342 52	3 40 342 52	3 50 342 52
		68	4	Lever	AISI 316	3 20 457 52	3 25 457 52	3 40 457 52	3 50 457 52
	69	4	Packing washer	PTFE	3 20 357 23	3 25 357 23	3 40 357 23	3 50 357 23	
BF2	as BF1 but:								
	1	1	Pump housing left for BF system	AISI 316	3 20 001 52	3 25 001 52	3 40 001 52	3 50 001 52	
		1	Pump housing right for BF system	AISI 316	3 20 301 52	3 25 301 52	3 40 301 52	3 50 301 52	
	65	8	O-ring for pump housing	PTFE	3 20 372 23	3 25 372 23	3 40 372 23	3 50 372 23	
BF3	as BF1 but:								
		65	8	O-ring for pump housing	FKM	3 20 372 09	3 25 372 09	3 40 372 09	3 50 372 09

16.7. High Pressure (option code HP)

DELLMECO diaphragm pumps can be fitted with High Pressure option. It is a very compact unit that can be mounted directly to the filter press. It has been designed for charging filter presses with chemical wastes and special sludge. An external pressure booster doubles or quadruples the delivery pressure.

Filter presses with DELLMECO HP pump

Automatic adaptation

When slurry is transferred to a chamber filter press, first the chambers get filled while the pressure tends to zero. Under the increasing filling-level the solids assemble at the filter cloths. This requires a pressure that continuously rises with the increasing content of solids. Under a constant flow quantity the pressure would rise extremely fast.

The drive of the HP pump by compressed air causes a diminution of the flow quantity according to the increasing counter-pressure in the filter press. This produces a soft filtration curve, automatically self-regulating according to the filling level of the filter press. This is independent from the properties of the slurry. No pressure tank nor pressure transmitter nor speed control are required. The complete HP pump works without electric energy.

End of filtration process

When the filter press is filled with the solids so far that no more slurry can be taken up, the pressing period is terminated. The air operation of the DELLMECO pumps then reduces the flow rate to zero while the outlet pressure holds the required level compressing the filter cake. Excellent results in drying are obtained. At the end of the pressing period the pump simply stops.

Pressure adjustment

The required pressure in the filter press is comfortably adjusted by the height of the air pressure supplying the charging station. For a required pressure of 12 bar the HP pump has to be supplied with 6 bar when the pump with a pressure transmission of 1:2 is applied. In the case that higher pressures are necessary or there is only a lower air pressure available, the HP pump with 1:4 transmission is applied.

Low air consumption

The charging stations need the maximum air quantity only during the filling period. The more the press is filled, the more slowly the pump works. So the air consumption slowly reaches zero during progressing filtration.

Appearance and dimensions of High Pressure pump

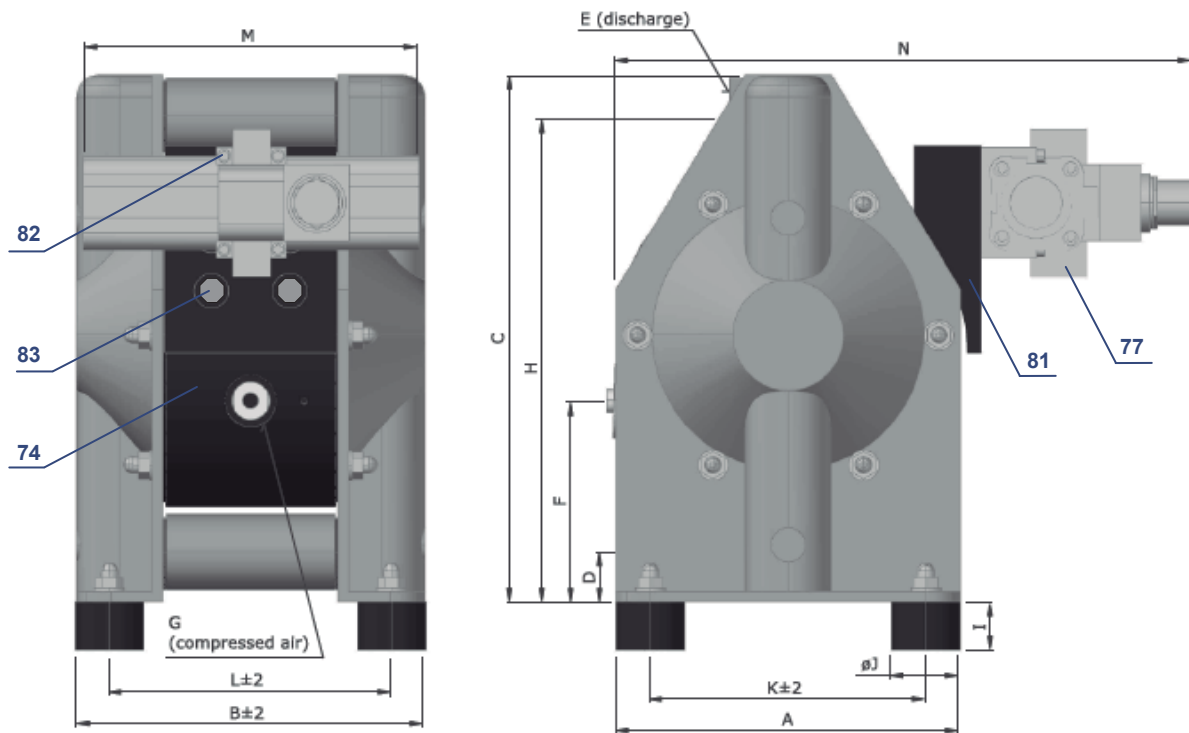

Pump model	A	B±2	C	D	E	F	G	H	I	ØJ	K±2	L±2	M	N
DM 20/75 HP	150	173	228	19	G ¾"	84	R 1/4"	209	18	30	118	139	195	297
DM 25/125 HP	200	202	302	27	G 1"	115	R 1/4"	279	18	30	160	164	195	351
DM 40/315 HP	270	267	412	34	G 1 ½"	100	R 1/2"	380	28	40	213	213	290	372
DM 50/565 HP	350	345	538	48	G 2"	115	R 1/2"	493	30	60	286	285	404	573

Spare part list, High Pressure system

Code	Item	Pcs.	Description	Material	DM 20	DM 25	DM 40	DM 50
					Part no.	Part no.	Part no.	Part no.
HP	74	1	Center housing for HP option	PE conductive	1 15 210 21	1 25 210 21	1 40 210 21	1 50 210 21
	77	1	Air pressure booster	diverse	9 15 64 00	9 15 64 00	9 40 64 00	9 50 64 00
	81	1	Booster connection	PE conductive	3 20 364 21	3 25 364 21	3 40 364 21	3 50 364 21
	82	4	Booster connection bolt	AISI 304	3 20 242 50	3 25 242 50	3 40 242 50	3 50 242 50
	83	4	Center housing connection bolt	AISI 304	3 20 442 50	3 25 442 50	3 40 442 50	3 50 442 50

Performance curves for High Pressure pumps

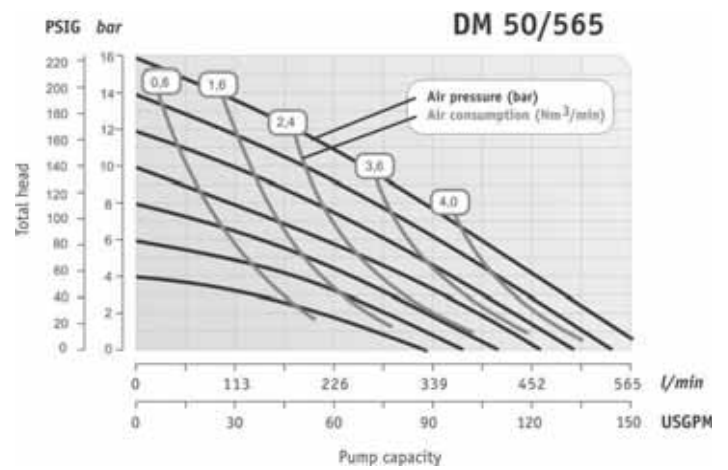
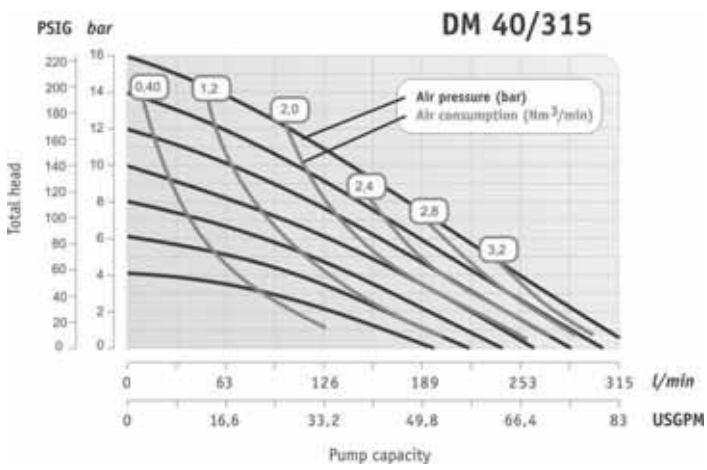
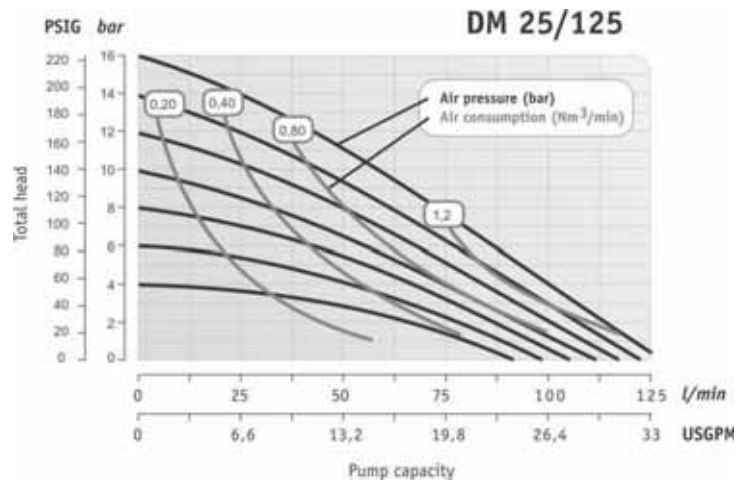
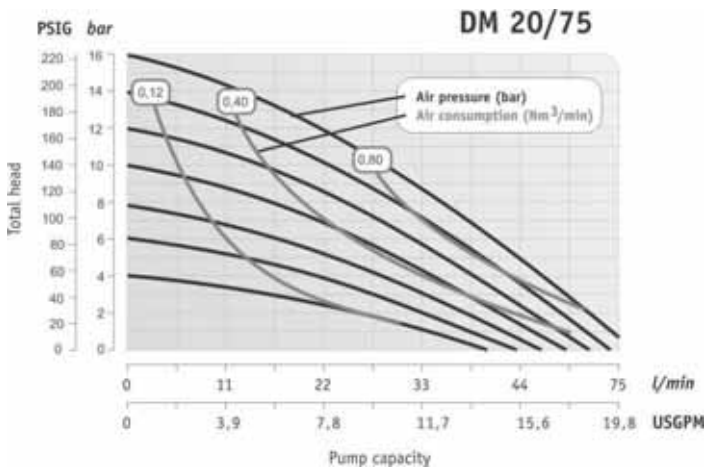

16.8. Heating Jacket (option code HJ) - AISI 316 only

The heating jacket is used when the pumped product has to maintain a specific temperature, high or low, throughout the process. A heating or cooling medium (hot water, steam, oil) is continuously circulated in the heating jacket. The jacket is covering all the wetted parts of the pump. Available on all industrial (AISI 316) series pumps.

Technical data for Heating Jacket (option code HJ):

- Maximum temperature: 120°C
- Maximum pressure: 3 bar
- Flow rate: depending on product temperature
- Medium: hot water, steam, oil
- Connections: 3/8"

Appearance of industrial pump with Heating Jacket option

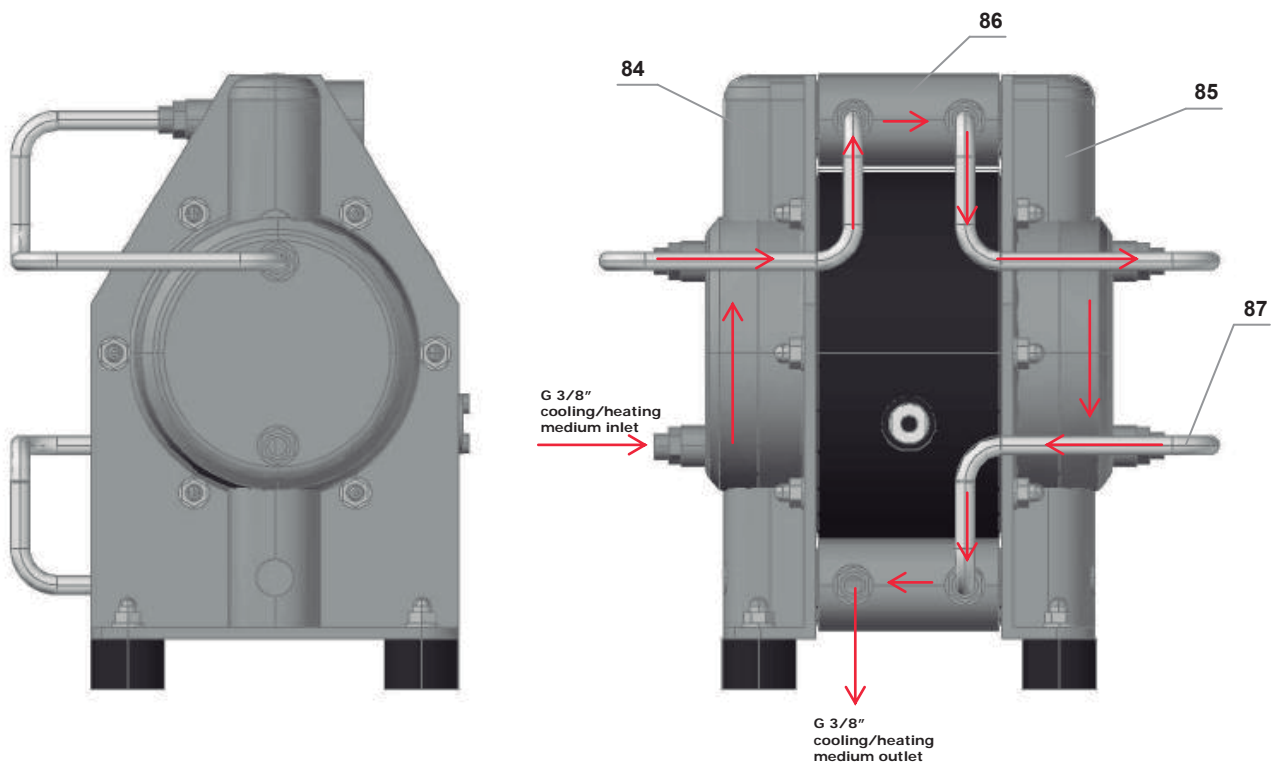

Spare part list, Heating Jacket option

Code	Item	Pcs.	Description	Material	Part no.	Part no.	Part no.	Part no.
HJ	84	1	Left side housing for HJ option	AISI 316	3 20 801 52	3 25 801 52	3 40 801 52	3 50 801 52
	85	1	Right side housing for HJ option	AISI 316	3 20 901 52	3 25 901 52	3 40 901 52	3 50 901 52
	86	2	Inlet/outlet for HJ option	AISI 316	3 20 130 52	3 25 130 52	3 40 130 52	3 50 130 52
	87	3	Hose connection	diverse	3 20 92 00	3 25 92 00	3 40 92 00	3 50 92 00

16.9. Powder Pump (option code P) – Aluminium only

DELLMECO Pumps can also transfer and handle dry process powders more quickly, cleanly and at a fraction of the cost associated with installed systems. Available on Aluminium Pump series (from model DM 20/75 A.. up to model DM 50/565 A..).

Appearance of Aluminium Pump with Powder option

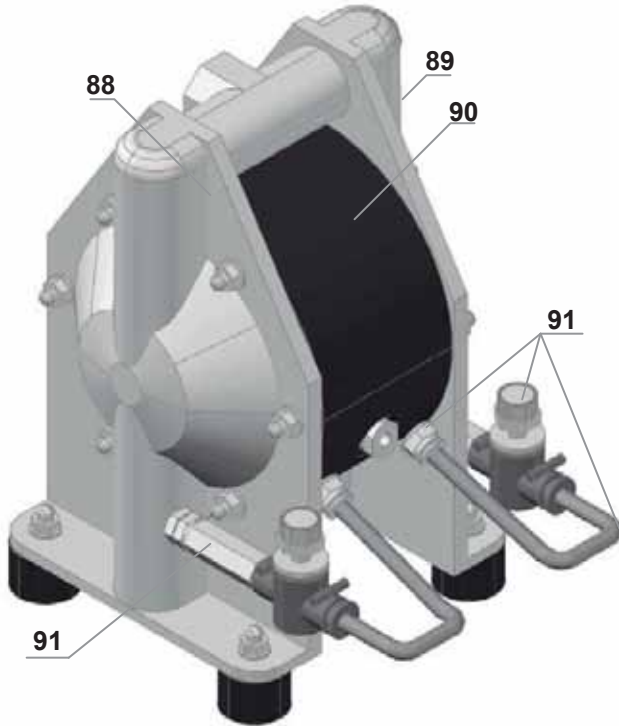

Spare part list, Powder option

Code	Item	Pcs.	Description	Material	DM 20	DM 25	DM 40	DM 50
					Part number			
P	88	1	Left side housing for Powder option	Aluminium	3 20 401 60	3 25 401 60	3 40 401 60	3 50 401 60
	89	1	Right side housing for Powder option	Aluminium	3 20 501 60	3 25 501 60	3 40 501 60	3 50 501 60
	90	1	Center housing for Powder option	PE cond.	3 20 010 21	3 25 010 21	3 40 010 21	3 50 010 21
	91	2	Connection for Powder option, cpl.	diverse	3 20 61 00	3 20 61 00	3 20 61 00	3 20 61 00

17. Limited warranty

This product is shipped to customers only after meeting strict inspection standards. If an abnormality occurs during normal operation in accordance with the operating instructions and other operating cautions within the warranty period (24 months after date of purchase) that can be attributed to a manufacturing defect, the defective parts of this product will be serviced or the product will be replaced free of charge. However, this warranty will NOT cover compensation for incidental damage or any malfunction listed below.

1. Warranty period

This warranty is valid for 24 months after the date of purchase.

2. Warranty

If, during the warranty period, any of the material of the genuine parts of this product or the workmanship of this product is found defective, and is so verified by our company, the servicing cost will be fully covered by our company.

3. Exclusion

Even during the warranty period, this warranty DOES NOT cover the following:

- 1) Malfunction caused by the use of parts other than manufacturer-specified genuine parts.
- 2) Malfunction caused by misuse or operating errors, or lack of storage or maintenance care.
- 3) Malfunction caused by the use of a fluid that may cause corrosion, inflation or dissolution of the component parts of the product.
- 4) Irregularity caused by a repair made by other than our firm, our regional office, dealer or authorized service personnel.
- 5) Malfunction caused by a modification of the product by other than authorized service personnel.
- 6) Wear and tear of parts that must be regularly replaced in the course of normal operation, such as diaphragms, valve seats, balls, air motor sleeve valves and o-rings.
- 7) Malfunction and/or damage due to transportation, moving or droppage of the product after purchase.
- 8) Malfunction and/or damage due to fire, earthquake, flood or other force majeure.
- 9) Malfunction caused by the use of compressed air that contains impurities, air with oil or excessive moisture, or use of gases or fluids other than the specified compressed air.
- 10) Malfunction caused by the use of a fluid that causes excessive abrasion.

Furthermore, this warranty does not cover the rubber parts, or other parts that are subject to wear in normal operation, used in this product and its accessories.

4. Parts

Parts for this product will be kept available for 5 years after discontinuation of production. Once 5 years have elapsed after close of production, availability of parts for this product cannot be guaranteed.

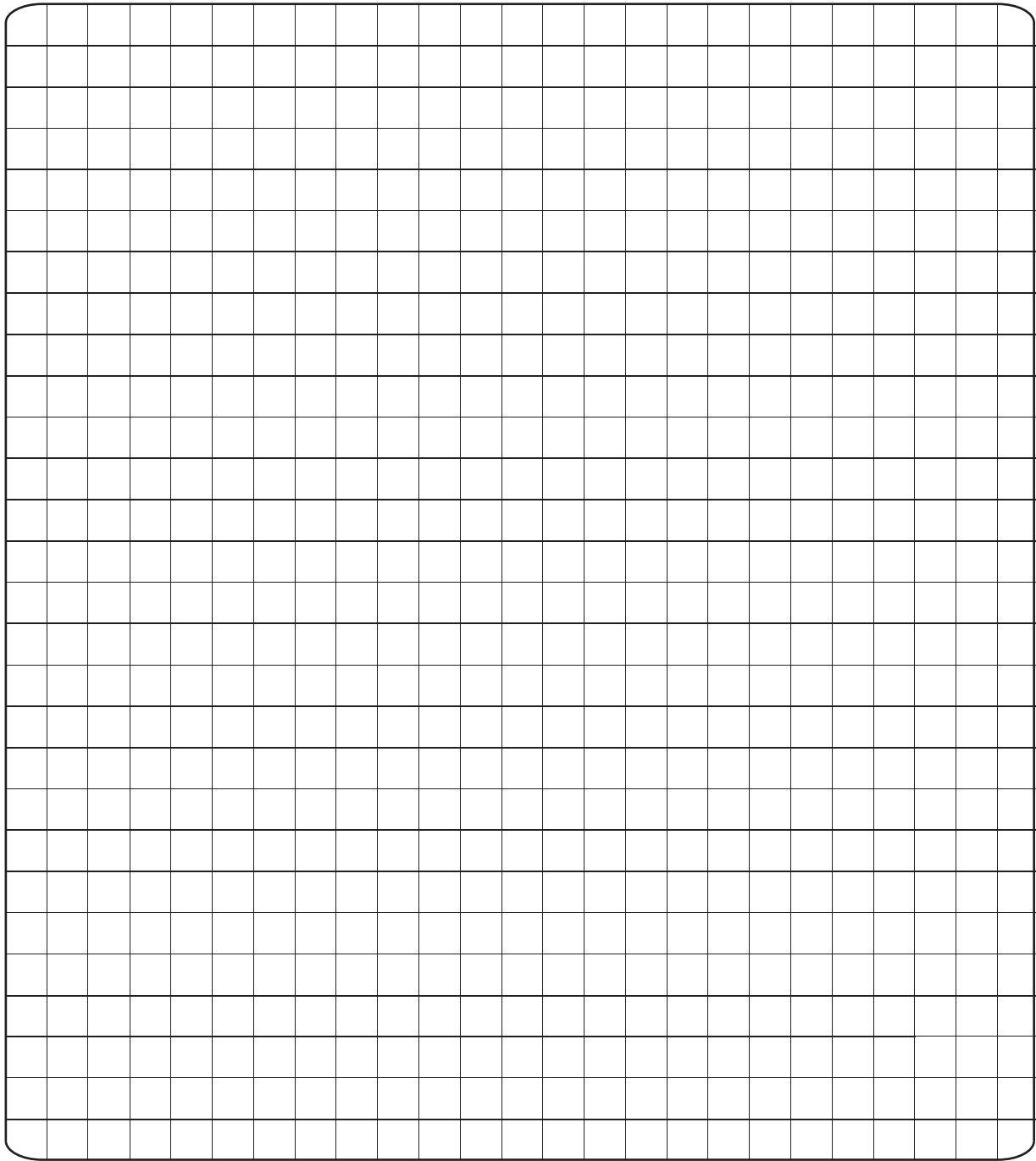

DELLMECO LTD

Unit 1, Willow Row
Longton
Stoke on Trent
Staffordshire
ST3 2PU
United Kingdom
tel. +44 1782 793 029
fax: +44 1782 501 721



sales@dellmeco.com
www.dellmeco.com