

# PRORIL

50 Hz

GOVOX Series, these vortex pumps feature a less impeller wear and longer pump life by a vortex flow that allows fibrous materials and solid matters to be pumped out without obstruction.

Sewage Pump

## GOVOX 204

Vortex Pump



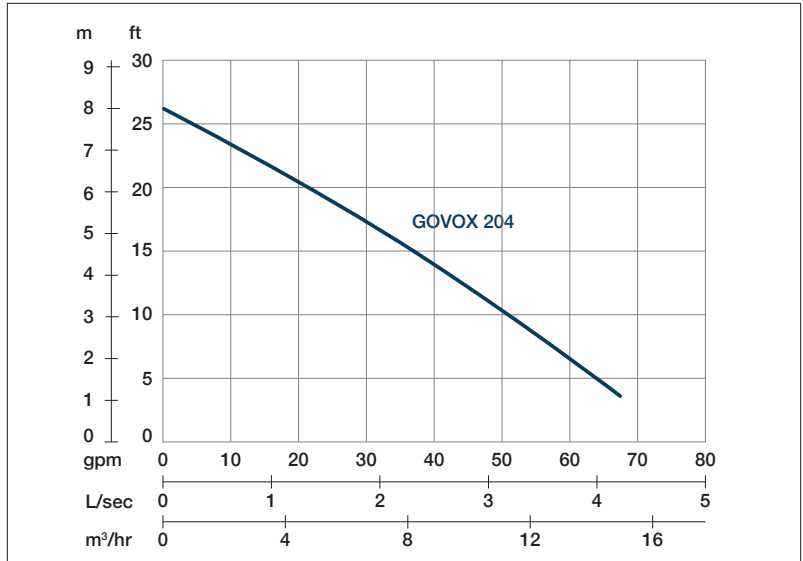

Shaft Speed : 2850 rpm    Solid Passage : 32 mm    Outlet : 50mm, 2in

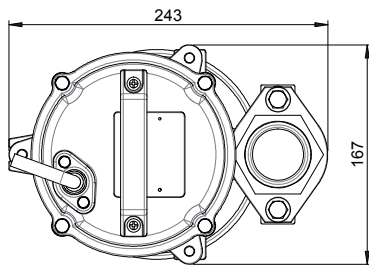

OUTPUT	HEAD	FLOW
0.4 kW	Rated : 5m, 16ft	Rated : 2 l/s, 32 gpm
0.5 HP	Max : 8m, 26ft	Max : 4 l/s, 66 gpm

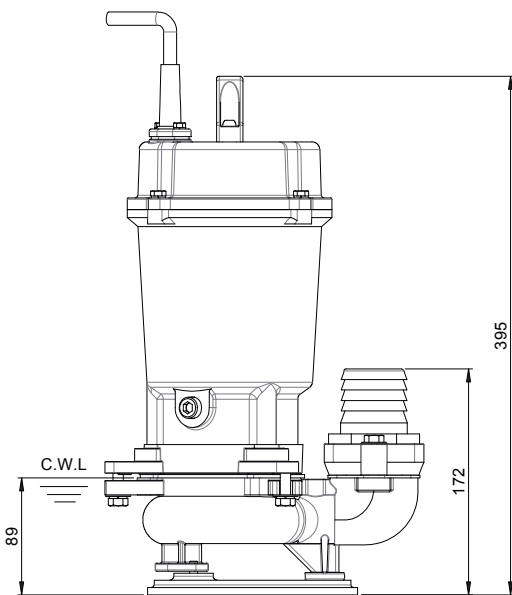

Weight : 13.5kg / 30 lbs

Pump Type		Electric Submersible Pumps
		1-Phase, 3-Phase
Motor	Type	Induction Motor
	Poles	2 Pole
	Insulation	Class F
	Protector	Circle Thermal Protector
	Starter	1-Phase • Capacitor-Run
Lubricant		Food Grade (ISO VG32)
Impeller Type		Vortex
Shaft Seal		Double Mechanical Seal
		Silicon Carbide VS Ceramic / Carbon
Bearings		C3 Shielded ball bearings
Cable		H07RNF
		Length: 10m (33ft) or longer upon request.
Materials	Pump Casing	Gray Iron
	Impeller	Gray Iron
	Motor Frame	Gray Iron
	Motor Shaft	Stainless Steel
Max. Liquid Temperature		104°F (40°C)
Max. Submersion Depth		66ft (20m)
pH Range		pH 5 - pH 8
Accessories		GRL-02