

# DELLMECO®

AODD DIAPHRAGM PUMPS

## Air Operated Double Diaphragm Pumps



## PUMP FEATURES

FOOD, PROCESSING,  
BEVERAGE, BIOTECH  
AND PHARMACEUTICAL



CHEMICAL AND  
PETROCHEMICAL



PAINTS, RESINS  
INKS AND COATINGS



OIL, GAS AND  
AUTOMOTIVE



SURFACE  
TREATMENT



CERAMIC  
SLIP/GLAZE



SEWAGE  
TREATMENT



DRY POWDER  
HANDLING



MINING AND  
CONSTRUCTION



PAPER  
INDUSTRY



- Compact, solid design - low space required
- Pumps abrasive and shear-sensitive materials. Low internal velocities handle abrasive liquids with no damage to the pump. The gentle pumping does not shear fragile materials
- Pumps move everything from water to very viscous liquids with solids
- Sealless - are environmentally friendly, no seals or packing to leak
- Safe in hazardous areas - air driven - non sparking
- Can run dry without damage
- Self-priming to over 9 meters
- Variable flow - simply regulate the inlet air supply to adjust the pump flow from zero to max flow
- Pump stalls if discharge is closed and restarts when discharge is opened (no heat build-up, or wear). Expensive types systems and pressure relief valves not required
- Composite, long life diaphragms for heavy applications (no diaphragm discs) is smooth and not interrupted by any seals whatever
- Operates without any lubrication
- Fully groundable
- Easy maintenance
- Certifications

CE Ex ATEX





### SELF PRIMING APPLICATION

Pumps range in suction lift capability for 5 meters dry. 9 meters can be reached in a primed condition. Suction lift will vary according to materials of construction and application parameters. All data is based on pumping water at 20°C.

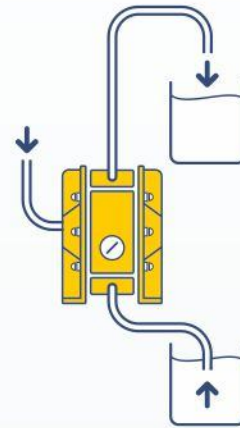

### SUBMERGED OPERATION

All pumps can operate in full submersion. Construction materials must be compatible with the surrounding liquid and the exhaust must be placed above the liquid level.

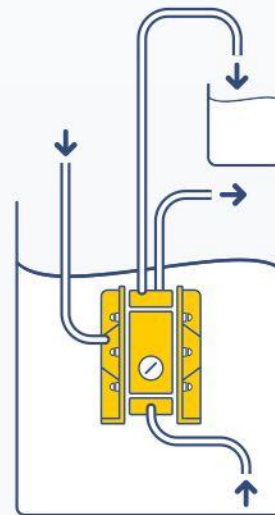

### POSITIVE SUCTION HEAD

Common as a method of drawing off the bottoms of holding tanks or clarifiers. Optimum inlet pressure should be kept at 0.2-0.3 bar.

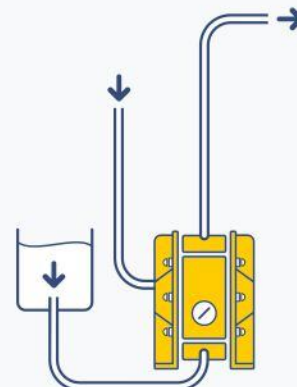

## PUMP CODE

<p><b>DM 15/55 PTS-DM 1</b></p> <p><b>DM</b> - Dellmeco Pump  <b>15</b> - Port dimension, DN  <b>55</b> - Max capacity l/min at 8 bar</p>	
<p><b>P - Housing material:</b></p> <p><b>A</b> - Aluminium  <b>B</b> - Aluminium coated with PTFE  <b>C</b> - Cast Iron  <b>H</b> - AISI 316L Hygienic  <b>P</b> - PE  <b>R</b> - PE conductive  <b>S</b> - AISI 316 Industrial  <b>T</b> - PTFE  <b>Z</b> - PTFE conductive</p>	<p><b>DM 1 - Optional equipment:</b></p> <p><b>BC1</b> - Barrier Chamber with sensors (Napur)  <b>BC2</b> - Barrier Chamber as BC1 with controllers  <b>BC3</b> - Barrier Chamber as BC2, ATEX</p> <p><b>DM1</b> - Diaphragm Monitoring, Namur – ATEX  <b>DM2</b> - Diaphragm Monitoring with controller  <b>F1</b> - Flange Connection PN 10 with EPDM O-ring  <b>F2</b> - Flange Connection PN 10 with NBR O-ring  <b>F3</b> - Flange Connection PN 10 with FEP/FPM O-ring  <b>F7</b> - Flange Connection PN10 DIN 2576  <b>F8</b> - Flange Connection ANSI 150 RF-50  <b>F9</b> - Flange Connection PN16 DIN 2277/2278  <b>SC1</b> - Stroke sensor, ATEX  <b>SC2</b> - SC1 plus stroke counter  <b>SC3</b> - SC1 plus stroke counter - ATEX  <b>SC5</b> - Stroke counting pneumatical with pressure transmitter  <b>SC6</b> - SC5 plus stroke counter</p> <p><b>BF1</b> - Back flushing system, hand operated, EPDM seals  <b>BF2</b> - Back flushing system, hand operated, PTFE seals  <b>BF3</b> - Back flushing system, hand operated, FPM seals  <b>BF4</b> - Back flushing system, pneumatical, EPDM seals  <b>BF5</b> - Back flushing system, pneumatical, PTFE seals  <b>AF1, AF2</b> - Air filter, regulator, valve, nipple, connector</p>
<p><b>T - Diaphragm material: (all conductive)</b></p> <p><b>E</b> - EPDM  <b>N</b> - NBR  <b>T</b> - TFM/PTFE</p>	<p><b>D</b> - Drum pump  <b>HJ</b> - Heating Jacket  <b>HP</b> - High Pressure  <b>MV</b> - pump with solenoid valve  <b>S</b> - Sleeve with split connections  <b>P</b> - Powder pump  <b>T</b> - Trolley</p>
<p><b>S - Material and kind of valve:</b></p> <p><b>E</b> - EPDM, ball valve  <b>N</b> - NBR, ball valve  <b>S</b> - AISI 316, ball valve  <b>T</b> - PTFE, ball valve  <b>U</b> - Polyurethane, ball valve  <b>F</b> - PTFE, cylinder valve  <b>P</b> - PE, cylinder valve  <b>C</b> - Ceramic, ball valve</p>	<p><b>CLEAN</b> - the Clean package to meet enlarged purity requirements for special pump applications</p>

## MATERIALS PROFILE

MATERIALS PROFILE	OPERATING TEMPERATURES		
	MIN	MAX	
<p><b>NBR</b> General purpose, oil-resistant. Shows good solvent, oil, water, and hydraulic fluid resistance. Should not be used with highly polar solvents like acetone and MEK, ozone, chlorinated hydrocarbons and nitro hydrocarbons</p>	30°C	90°C	<p>PE (polyethylene) is very tough and exceedingly resistant to wear, its water absorption capacity is very low and it displays good general resistance to chemicals. Only such strong oxidants as nitric acid, oleum and halogens can damage PE.</p> <p>PE competes with PP (polypropylene) which is frequently used in the manufacture of pumps. Thermally and chemically speaking, there are virtually no differences between these two. However, the similarity ends where the mechanical properties are concerned: trials based on the sand-slurry method have shown that the abrasion resistance of the PE is 7 times higher than that of PP and even 1.6 times higher than that of steel. It is certainly also more wear-resistant than, for example, cast iron or aluminum. This high resistance to abrasion plays a vital role in many applications (e.g. pickling baths in the electroplating industry, printing inks, lime slurry for wet de-sulphurization, ceramic mass and glazes in the ceramic industry).</p>
<p><b>EPDM</b> Shows very good water and chemical resistance. Has poor resistance to oil and solvents, but is fair in ketones and alcohols.</p>	-40°C	120°C	<p>PTFE is a thermoplastic polymer of tetrafluoroethylene. It has a smooth surface, a very low friction coefficient, is physiologically safe, can be used over a wide range of temperatures and displays virtually universal resistance to chemicals. However, pure PTFE has very little resistance to abrasion and tends to cold-flow.</p>
<p><b>Virgin PTFE.</b> Chemically inert, virtually impervious. Very few chemicals are known to chemically react with PTFE; molten alkali metals, turbulent liquid or gaseous fluorine and few fluoro-chemicals such as chlorine trifluoride or oxygen difluoride with readily liberate free fluorine at elevated temperatures.</p>	-37°C	120°C	

Maximum and minimum temperatures are the limits for which these materials can be operated. Temperatures coupled with pressure affect the longevity of diaphragm pump components. Maximum life should not be expected at the extreme limits of the temperature ranges.



## A. HOW TO SELECT PUMP SIZE

- 1) Enter Flow (l/min) and Head  
(example: 50 l/min at 4 bar)
- 2) Approximate energy requirements in Pressure and Volume  
(example: 0,40 Nm<sup>3</sup>/min at 6 bar)

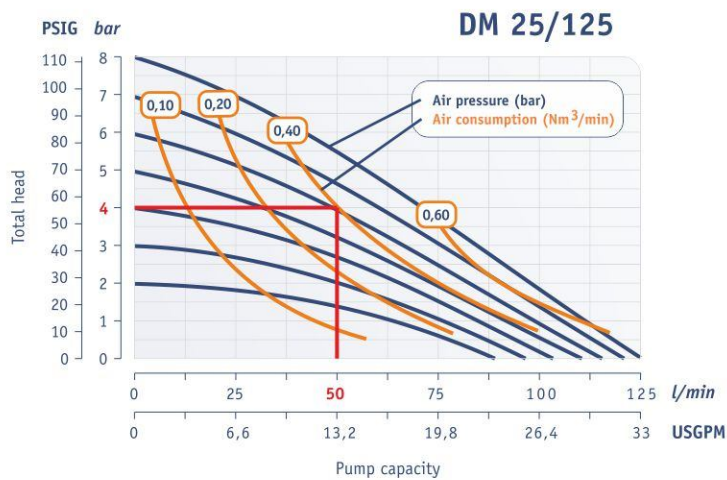

1" Pump - Performance Curve  
Performance based on water at 20°C

## B. RECOMMENDED INSTALLATION GUIDELINES

For best results DELLMECO recommends installing the pulsation damper on the discharge side of the pump.

To reduce piping and pump connection stresses, we recommend flexible connections on both inlet and outlet piping and air inlet connections.

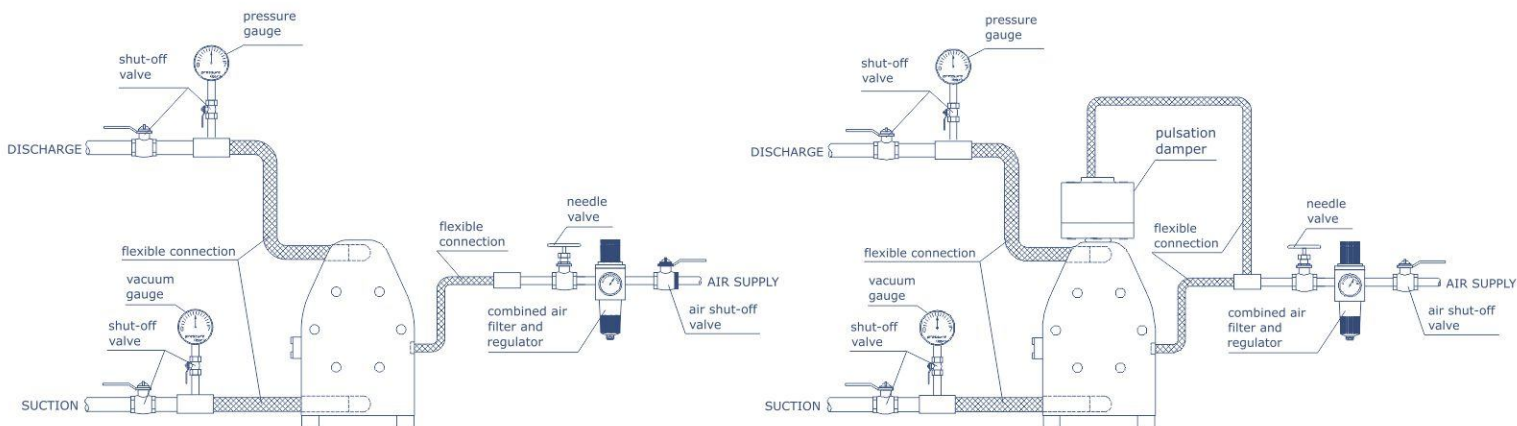

- 1) Connect a flow valve and a drain valve to the fluid discharge port of the pump.
- 2) Connect a valve for maintenance to the fluid suction intake port of the pump.
- 3) Connect a hose to the valve on the suction-port side and the valve of the discharge-port side of the pump.
- 4) Connect a hose on the suction-side intake and the discharge-port side to the respective vessels.

## C. REDUCTION OF FLOW RATE

Product viscosity affects pump capacity.

The capacity specified in the pump performance charts generally refer to water (1cPs).

The value must be reduced correspondingly when pumping media with higher viscosity. The design capacity can be read off directly from the graph and the corresponding pump size selected.

The example shown here is based on required capacity of 200 l/min with a product viscosity of 2000 cPs. The dash-dotted line intersects the design capacity scale at 248 l/min.

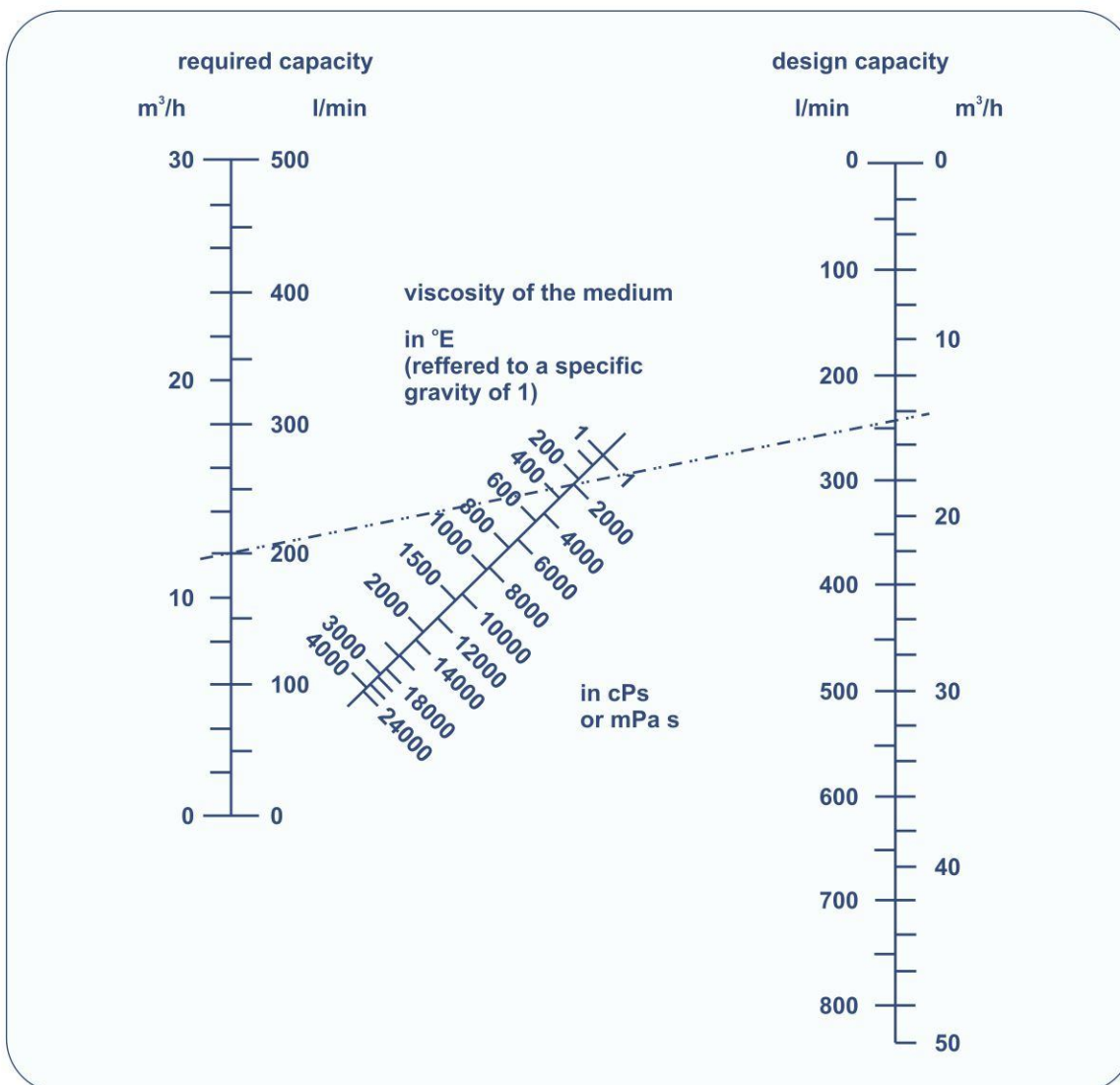



## POLYETHYLENE AND PTFE PUMPS



### 1. Designed to succeed

- temperatures up to 120 °C
- pressure up to 14 bar
- lubrication-free operation
- low air consumption

### 2. Flexible installations

- BSP as standard,
- PN10, PN16, AISI316, ANSI, NPT, split manifold configurations available
- connections may rotate 180 °

### 3. Solid and strong

- housing machined from a solid PE, PTFE (and conductive)
- stand against aggressive chemicals
- gentle pumping action
- viscous product transfer

### 4. Perfect diaphragm

- completely smooth liquid side surface (no hole)
- no metal in contact with the liquid



## POLYETHYLENE AND PTFE MATERIALS

### DIMENSIONAL DRAWING

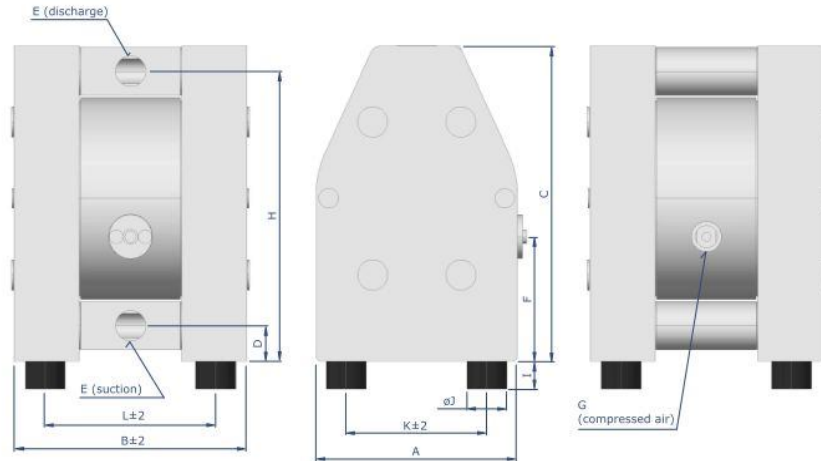

DIMENSIONS	A	B	C	D	E	F	G	H	I	ØJ	K	L
DM 08/10	70	113	120	15	G 1/4"	58	R 1/8"	107	10	15	50	86
DM 10/25	105	128	164	18	G 3/8"	84	R 1/8"	150	10	15	75	93
DM 15/55	153	177	235	25	G 1/2"	87	R 1/4"	217	18	30	112	136
DM 25/125	200	232	312	35	G 1"	123	R 1/4"	287	28	40	140	170
DM 40/315	270	312	426	42	G 1 1/2"	109	R 1/2"	388	30	60	190	227
DM 50/565	350	385	540	45	G 2"	158	R 1/2"	485	30	60	270	282
DM 80/800	480	580	800	100	G 3"	388	R 3/4"	690	40	75	395	495

## PUMP CODE

	08/10	10/25	15/55	25/125	40/315	50/565	80/800
Max capacity (l/min)	10	25	55	125	315	565	800
Max pressure (bar)	8						
Nominal port size	1/4"	3/8"	1/2"	1"	1 1/2"	2"	3"
Air connection	R 1/8"	R 1/8"	R 1/4"	R 1/4"	R 1/2"	R 1/2"	R 3/4"
Suction lift dry (mWC)	0.5/1.5*	2.0	3.0	4.0	4.0	5.0	5.0
Suction lift wet (mWC)	9.0						
Max diameter solids (mm)	2	3	4	7	10	12	15
Temperature limits - PE (°C)	70	70	70	70	70	70	70
Temperature limits - PTFE (°C)	110	110	120	120	120	120	120
Weight- PE (kg)	0.9	1.4	5	9	23	42	170
Weight - PTFE (kg)	1.4	2.4	7	16	43	87	-
Material of pump housing	PE, PTFE						PE
Diaphragm options	TFM/PTFE	NBR, EPDM or TFM/PTFE					
Valve balls	PTFE, AISI 316	NBR, EPDM, PTFE, AISI 316, PU					NBR, EPDM, PTFE
Rod valves	PTFE		PE or PTFE				-
O-rings	NBR, EPDM, FEP/FPM, PTFE+EPDM or PTFE+FPM						

\* 0.5 m for ball valves, 1.5 m for rod valves





## WHERE ATEX IS REQUIRED

The plastic pumps manufactured of conductive PE and PTFE are constructed to enable grounding of non-metallic pumps. This feature allows the pump to safely transfer solvents, alcohols and other volatile liquids without the danger of static electricity build-up. These features apply also to the aluminium, cast iron and AISI 316 pumps.

## DIMENSIONAL DRAWING

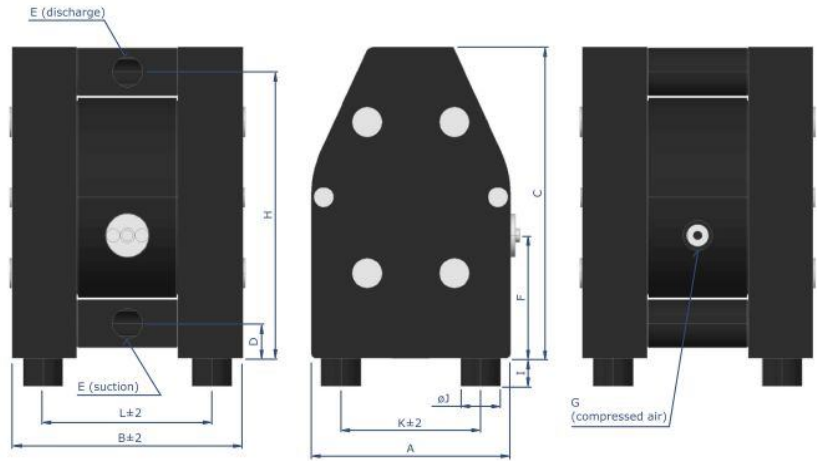

DIMENSIONS	A	B	C	D	E	F	G	H	I	ØJ	K	L
DM 08/10	70	113	120	15	G 1/4"	58	R 1/8"	107	10	15	50	86
DM 10/25	105	128	164	18	G 3/8"	84	R 1/8"	150	10	15	75	93
DM 15/55	153	177	235	25	G 1/2"	87	R 1/4"	217	18	30	112	136
DM 25/125	200	232	312	35	G 1"	123	R 1/4"	287	28	40	140	170
DM 40/315	270	312	426	42	G 1 1/2"	109	R 1/2"	388	30	60	190	227
DM 50/565	350	385	540	45	G 2"	158	R 1/2"	485	30	60	270	282
DM 80/800	480	580	800	100	G 3"	388	R 3/4"	690	40	75	395	495

## ATEX CE II 2GD TX

## PUMP CODE

	08/10	10/25	15/55	25/125	40/315	50/565	80/800
Max capacity (l/min)	10	25	55	125	315	565	800
Max pressure (bar)	8						
Nominal port size	1/4"	3/8"	1/2"	1"	1 1/2"	2"	3"
Air connection	R 1/8"	R 1/8"	R 1/4"	R 1/4"	R 1/2"	R 1/2"	R 3/4"
Suction lift dry (mWC)	0.5/1.5*	2.0	3.0	4.0	4.0	5.0	5.0
Suction lift wet (mWC)	9.0						
Max diameter solids (mm)	2	3	4	7	10	12	15
Temperature limits - PE (°C)	70	70	70	70	70	70	70
Temperature limits - PTFE (°C)	110	110	120	120	120	120	120
Weight- PE (kg)	0.9	1.4	5	9	23	42	170
Weight - PTFE (kg)	1.4	2.4	7	16	43	87	-
Material of pump housing	PE conductive, PTFE conductive						PE conductive
Diaphragm options	TFM/PTFE	NBR, EPDM or TFM/PTFE					
Valve balls	PTFE, AISI 316	NBR, EPDM, PTFE, AISI 316, PU					NBR, EPDM, PTFE
Rod valves	PTFE		PE or PTFE				-
O-rings	NBR, EPDM, FEP/FPM, PTFE conductive +EPDM or PTFE conductive +FPM						

\* 0.5 m for ball valves, 1.5 m for rod valves

ATEX pumps are designed to meet ATEX regulations for pneumatic diaphragm pumps handling flammable liquids. All material construction with approved NBR, EPDM or PTFE/TFM elastomers.



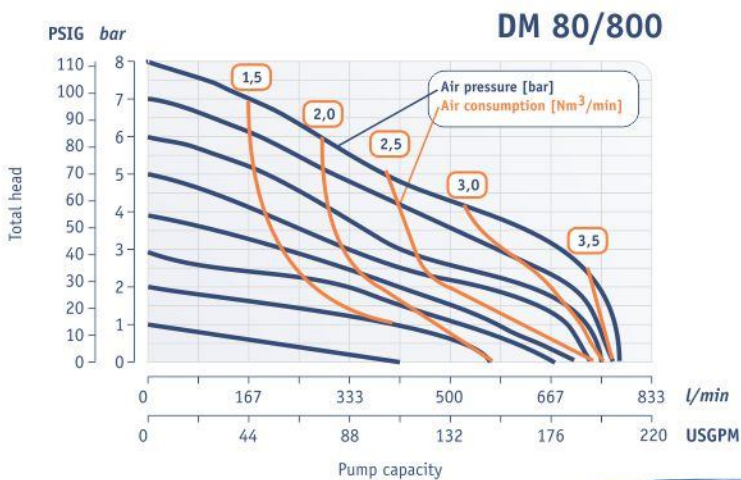
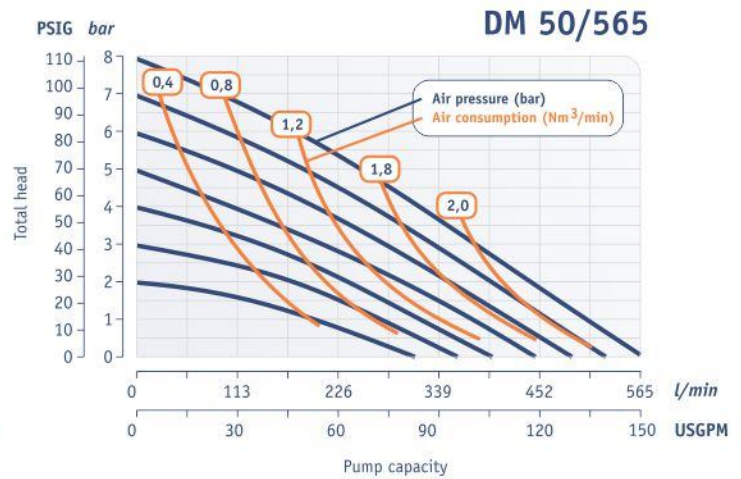
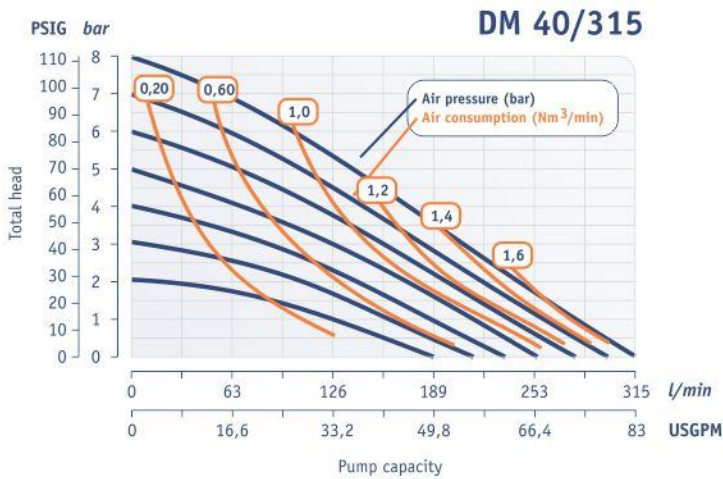
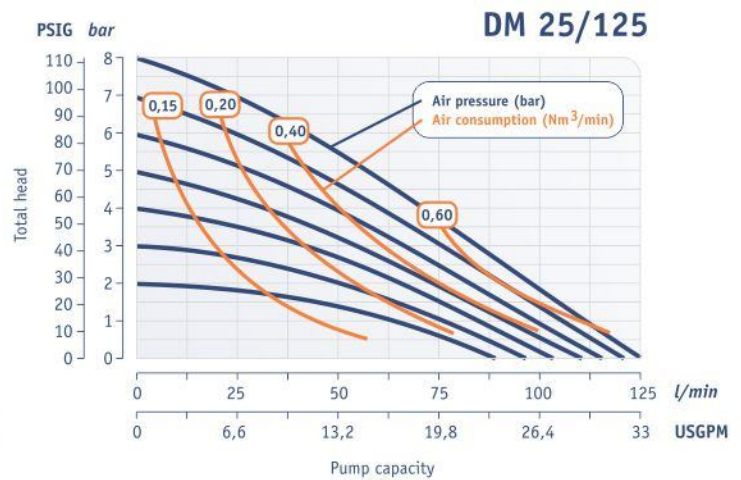
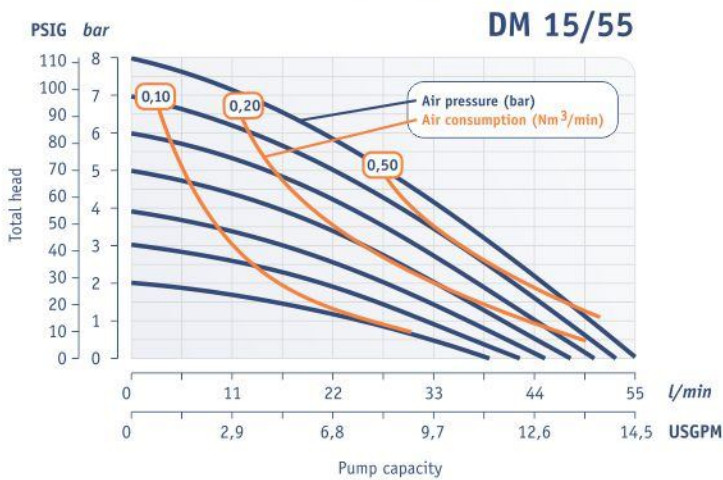
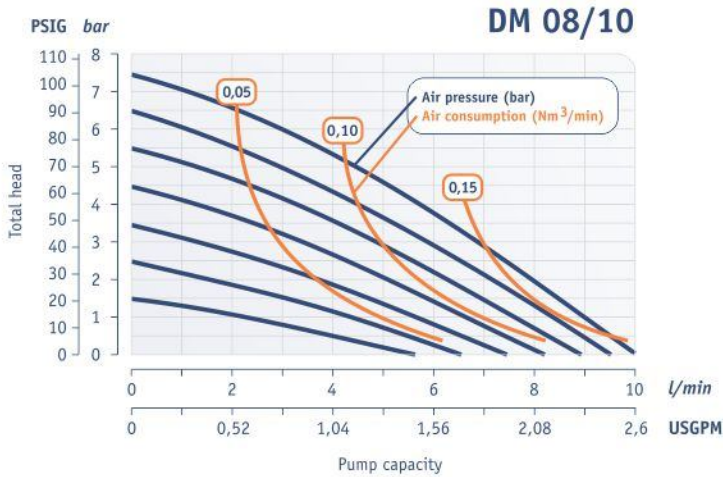



## METAL PUMPS

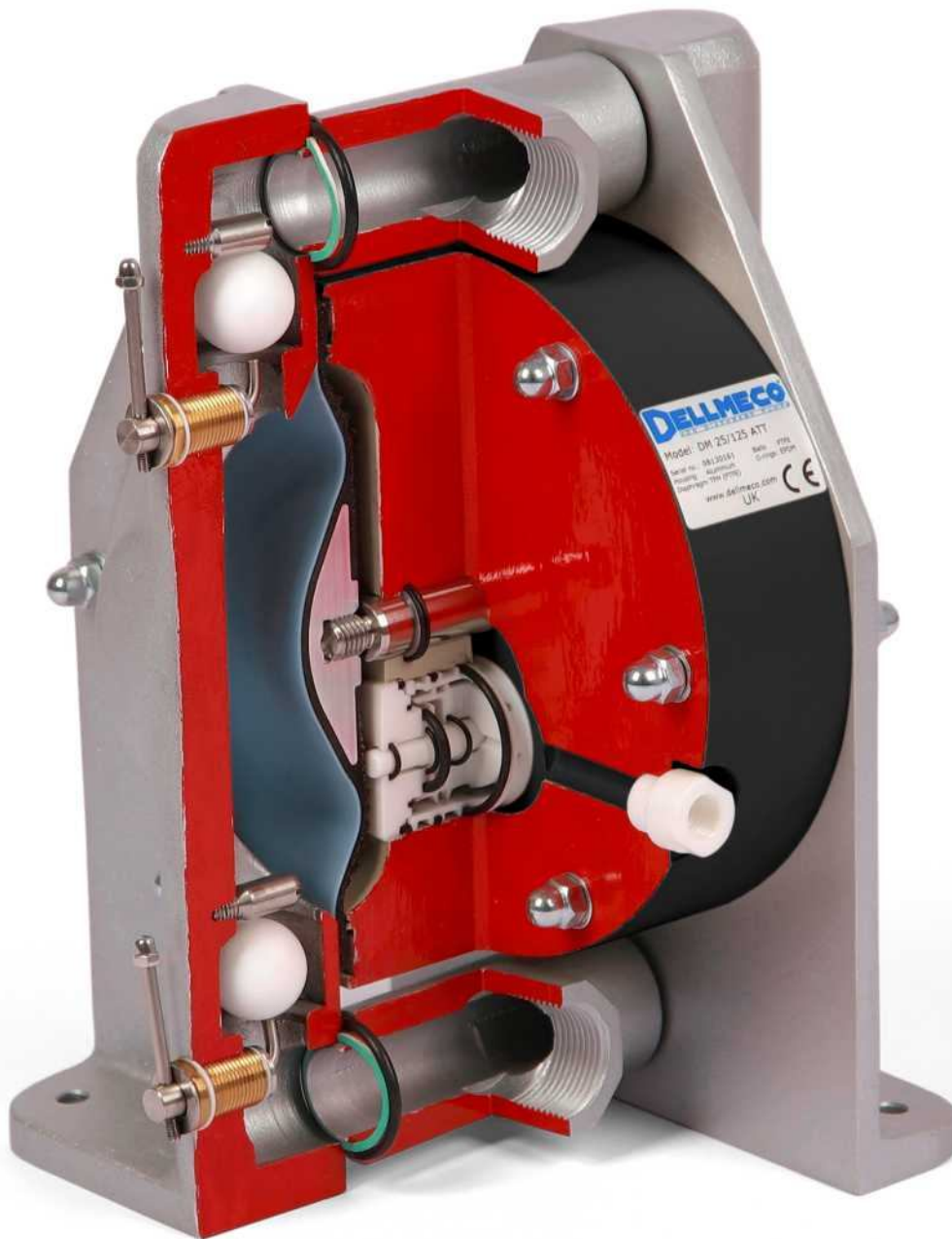

### 1. Designed to succeed

- temperatures up to 120 °C
- pressure up to 14 bar
- lubrication-free operation
- low air consumption

### 2. Flexible installations

- BSP as standard,
- PN10, PN16, ANSI, NPT, split manifold configurations available
- connections may rotate 180°

### 3. Solid and strong

- gentle pumping action
- viscous product transfer
- the valve seat made of AISI 316 is integrated with pump housing

### 4. Perfect diaphragm

- completely smooth liquid side surface (no hole)
- no metal in contact with the liquid



## ALUMINIUM, ALUMINIUM WITH PTFE, CAST IRON

### DIMENSIONAL DRAWING

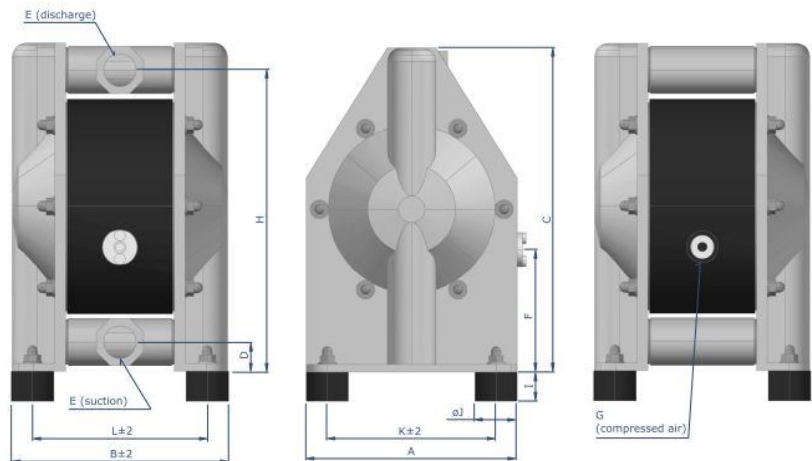

DIMENSIONS	A	B	C	D	E	F	G	H	I	ØJ	K	L
DM 15/25	104	122	166	17	G 1/2"	85	R 1/8"	153	10	15	84	98
DM 20/75	150	171	230	21	G 3/4"	84	R 1/4"	212	18	30	116	133
DM 25/125	200	202	305	27	G 1"	115	R 1/4"	280	28	40	160	164
DM 40/315	273	267	417	34	G 1 1/2"	110	R 1/2"	382	28	40	220	213
DM 50/565	352	345	546	48	G 2"	165	R 1/2"	501	30	60	282	281
DM 80/850	485	530	833	72	G 3"	364	R 3/4"	760	40	75	410	449

## TECHNICAL DATA

	15/25	20/75	25/125	40/315	50/565	80/850 **
Max capacity (l/min)	25	75	125	315	565	850
Max pressure (bar)	8					
Nominal port size	1/2"	3/4"	1"	1 1/2"	2"	3"
Air connection	R 1/8"	R 1/4"	R 1/4"	R 1/2"	R 1/2"	R 3/4"
Suction lift dry (mWC)	2.0	3.0	4.0	4.0	5.0	5.0
Suction lift wet (mWC)	9.0					8.0
Max diameter solids (mm)	3	4	7	10	12	15
Temperature limits - NBR, EPDM (°C)	80					
Temperature limits - PTFE (°C)	120					110
Weight - Alu (kg)	1.9	4.9	8	18	33	97
Material of pump housing	Aluminium, Aluminium Coated with PTFE, Cast Iron					Aluminium
Diaphragm options	NBR, EPDM or TFM/PTFE					
Valve balls	NBR, EPDM, PTFE, AISI 316, PU					NBR, EPDM, PTFE
O-rings	NBR, EPDM, or FEP/FPM					

\*\* - Aluminium version only





## STAINLESS STEEL AISI 316 - INDUSTRIAL

### DIMENSIONAL DRAWING

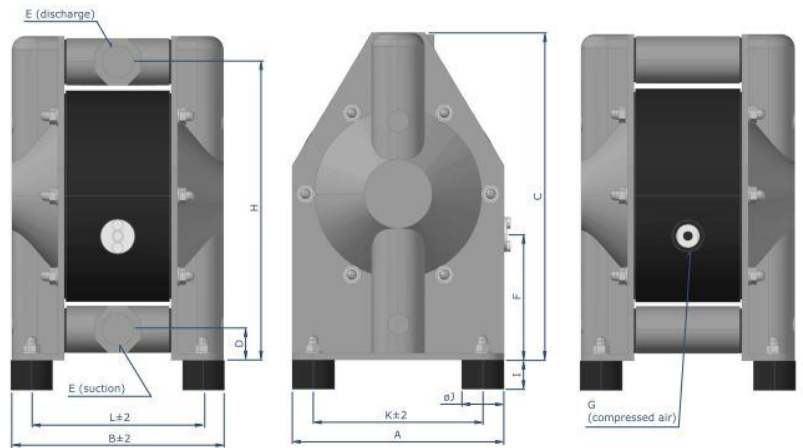

DIMENSIONS	A	B	C	D	E	F	G	H	I	øJ	K	L
DM 20/75	150	171	230	21	G 3/4"	86	R 1/4"	212	18	30	118	139
DM 25/125	200	202	306	29	G 1"	117	R 1/4"	282	28	40	160	164
DM 40/315	270	267	412	34	G 1 1/2"	110	R 1/2"	380	28	40	213	213
DM 50/565	350	345	538	48	G 2"	165	R 1/2"	493	30	60	286	285

## TECHNICAL DATA

	20/75	25/125	40/315	50/565
Max capacity (l/min)	75	125	315	565
Max pressure (bar)	8			
Nominal port size	3/4"	1"	1 1/2"	2"
Air connection	R 1/4"	R 1/4"	R 1/2"	R 1/2"
Suction lift dry (mWC)	3.0	4.0	4.0	5.0
Suction lift wet (mWC)	9.0			
Max diameter solids (mm)	4	7	10	12
Temperature limits - NBR, EPDM (°C)	80			
Temperature limits - PTFE (°C)	120			
Weight - AISI 316 (kg)	9.5	14	31	70
Material of pump housing	AISI 316			
Diaphragm options	NBR, EPDM or TFM/PTFE			
Valve balls	NBR, EPDM, PTFE, AISI 316, PU			
O-rings	NBR, EPDM, or FEP/FPM			

## SPECIAL MATERIAL VERSIONS



Aluminium coated with PTFE as alternative solution for AISI 316 pumps.  
Pump connection are made of AISI 316.  
Especially suitable for print and ink industry.



Cast iron Pump with PE-conductive (polyethylene conductive) center section.



## METAL PUMPS OPTIONS



Metal pump with heating jacket.



Metal pump with handle for drum option.

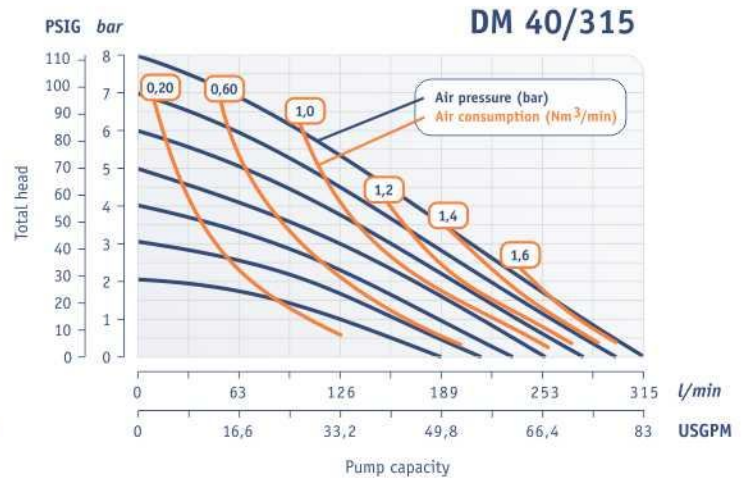
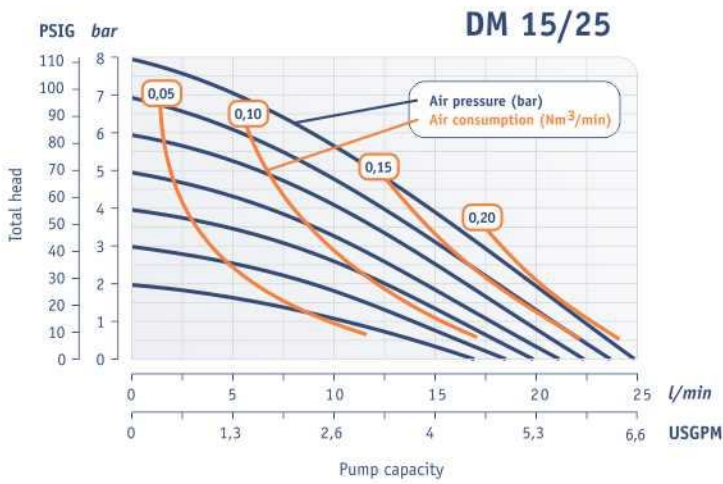



## SANITARY PUMPS

### HYGIENIC CONSTRUCTION



#### **1.Quick dismantling**

The clamp system ensures rapid dismantling without any tools.

#### **2.Plain surface**

The sandwich diaphragm has a completely plain surface, which eliminates bacteria growth problems. The diaphragm is available in food grade material - pure TFM (PTFE).

#### **3.Superior finish**

Both liquid side and outside is electropolished to obtain superior finish and hygiene. Special surface finish may be done according to your requirements.

#### **4.Pollution-free air valve**

The sealing system is lubrication-free, always keeping your product and environment free from oil contamination.



Hygienic design made from electropolished stainless steel to meet the requirements in hygienic installations.

## AISI 316L POLISHED - HYGIENIC PUMP

### DIMENSIONAL DRAWING

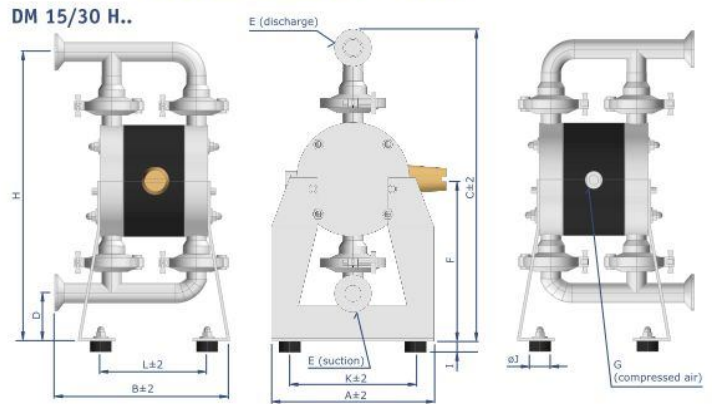

### DM 25/75 H.. - DM 65/565 H..

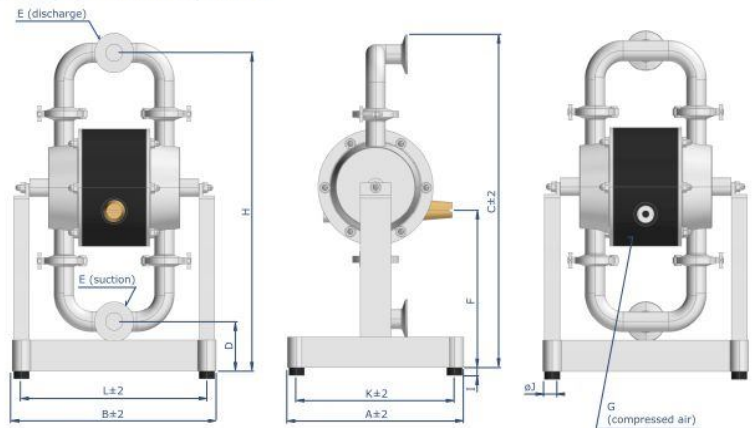

DIMENSIONS	A	B	C	D	E			F	G	H	I	øJ	K	L
					TC	DN	SMS							
DM 15/30	150	165	299	46	1/2"	15	-	162	R 1/8"	282	18	30	116	103
DM 25/75	230	264	419	75	1"	25	25	204	R 1/4"	394	18	30	206	238
DM 40/125	256	287	465	67	1 1/2"	40	38	221	R 1/4"	440	18	30	226	257
DM 50/315	350	387	679	102	2"	50	51	247	R 1/2"	640	18	30	325	357
DM 65/565	350	459	888	126	2 1/2"	65	63,5	357	R 1/2"	842	18	30	326	435

## TECHNICAL DATA

	15/30	25/75	40/125	50/315	65/565
Max capacity (l/min)	30	75	125	315	565
Max pressure (bar)	8				
Nominal port size	DN 15	DN 25	DN 40	DN 50	DN 65
Optional connections	DIN 11850 standard, Tri-Clamp, SMS				
Air connection	R 1/8"	R 1/4"	R 1/4"	R 1/2"	R 1/2"
Suction lift dry (mWC)	1.5	3.0	4.0	4.0	5.0
Suction lift wet (mWC)	9.0				
Max diameter solids (mm)	4	5	8	11	14
Temperature limits - NBR, EPDM (°C)	80				
Temperature limits - PTFE (°C)	120				
Weight (kg)	5	8	11	26	34
Material of pump housing	AISI 316L				
Material of centre housing	PE, PE conductive				
Diaphragm options	NBR, EPDM or TFM/PTFE				
Valve balls	NBR, EPDM, PTFE, AISI 316				
Gaskets	Silicone, PTFE, EPDM, NBR				

### Sanitary series

Sanitary series is particularly designed to meet the requirements of the food, beverage, pharmaceutical and cosmetic industries. Lubrication-free air distribution system, maintenance-free ball check valve system and total visual inspection of the wetted parts are some of the major features for this pump series.

### Made to be clean

Our design allows for total visual inspection of the wetted parts. There are no hidden areas where bacteria can grow. The manifold clamps and the housing screws are simply removed for complete disassembly and cleaning. The pump is also designed for cleaning and sterilization in place - C.I.P. and S.I.P. After such operations, the pump is easily turned in its support for drainage.



## SPECIAL VERSIONS

### TROLLEY FOR PUMP

Make your DELLMECO pump mobile. The trolley is available for all pump sizes.



### HEATING JACKET

The heating jacket is used when the pumped product has to maintain a specific temperature, high or low, throughout the process. A heating or cooling medium is continuously circulated in the heating jacket. The jacket is covering all the wetted parts of the pump. Available on all sanitary series pumps.





### VARIETY OF CONNECTION TYPES

The pump is supplied as standard with connections according to DIN 11850. However, the pump may be equipped with almost any type of connection used in the hygienic field – TriClamp, SMS, RJT, ANSI etc.

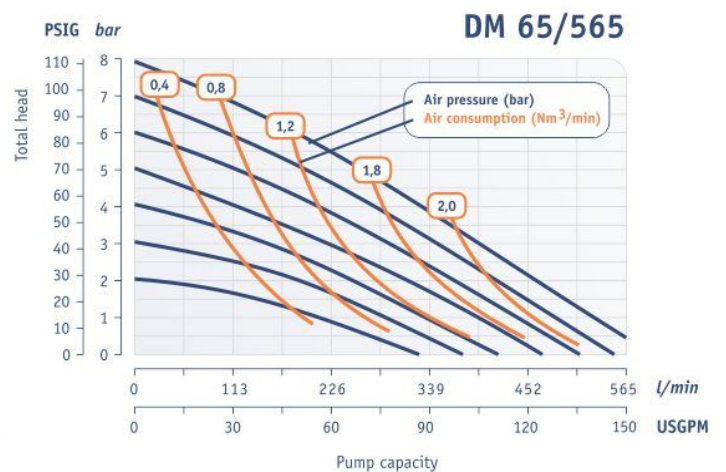
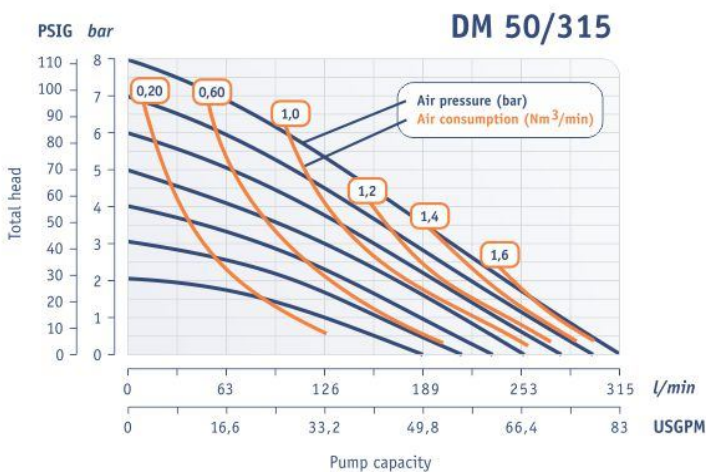
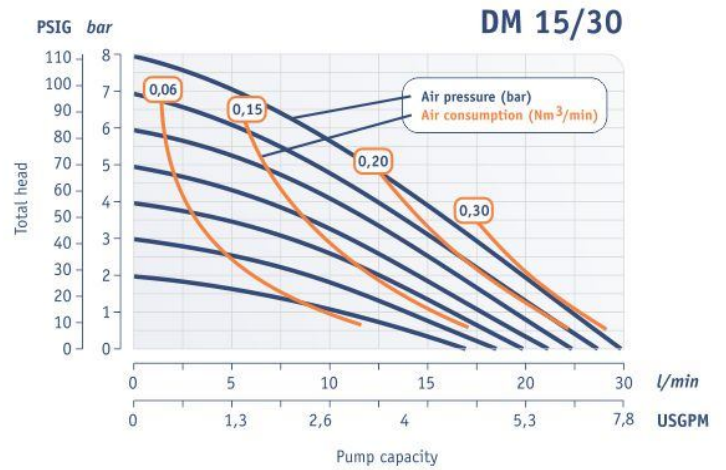



## HIGH PRESSURE PUMPS



HP - High Pressure pump station for filter press feeding is a very compact unit that can be mounted directly to the filter press. The design and function allows the user a straightforward pressing of slurries. Pressure regulator is already mounted to the unit. The pump stations are based on the standard DELLMECO pumps from machined polyethylene (PE). An external pressure booster doubles the delivery pressure. For example, with available air pressure of 7bar, the delivery pressure will be maximum 14bar.

### DIMENSIONAL DRAWING - POLYMER

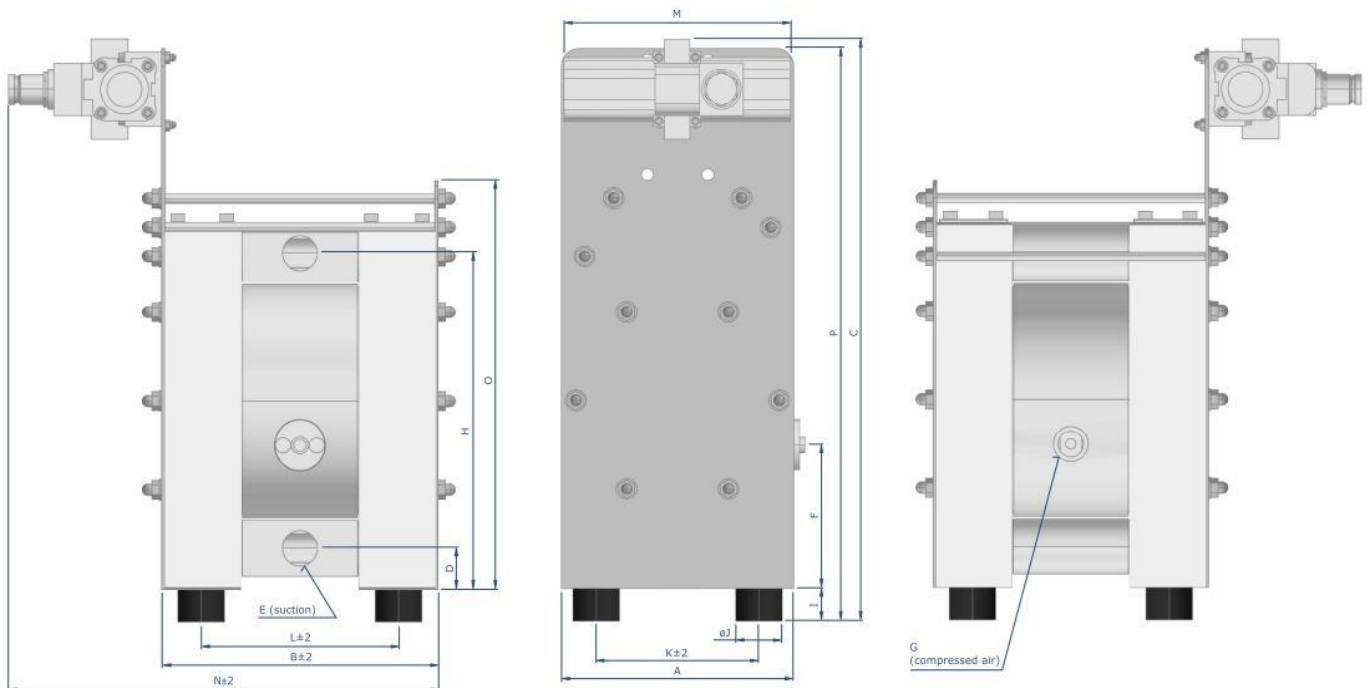

DIMENSIONS	A	B	C	D	E	F	G	H	I	øJ	K	L	M	N	O	P
DM 15 /55	153	183	335	25	G 1/2"	87	R 1/4"	217	18	30	112	136	195	321	253	333
DM 25/125	200	238	469	35	G 1"	123	R 1/4"	287	28	40	140	170	195	377	349	462
DM 40/315	270	318	600	42	G 1 1/2"	109	R 1/2"	388	30	60	190	227	290	529	500	600
DM 50/565	350	391	690	45	G 2"	158	R 1/2"	485	30	60	270	282	404	612	560	690



## INSTALLATION

As this station works self-regulating, an additional device for regulating the flow quantity is not necessary. Just mount it to the filter-press, connect it - ready. Even the pressure regulator for the air supply is included. For monitoring the filling level of the filter-press, stroke sensors and stroke counters are available. Pump is self priming, can run dry.

## DIMENSIONAL DRAWING - METAL

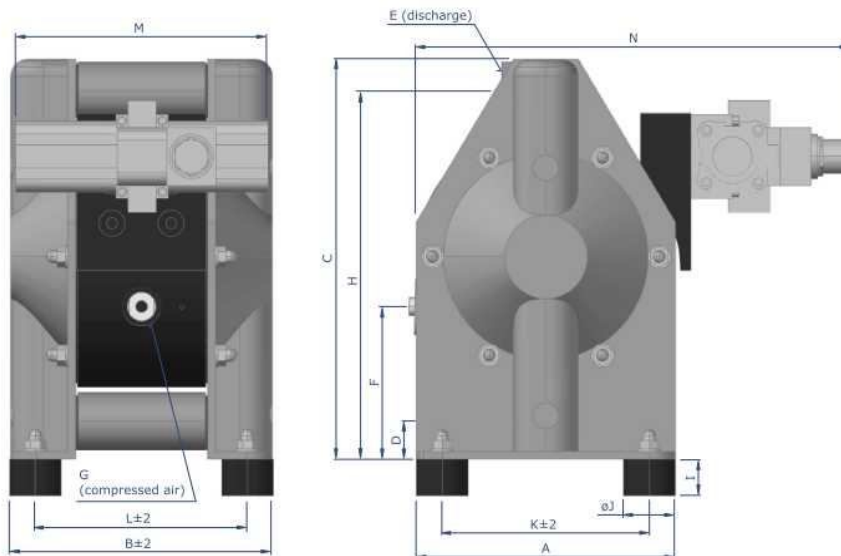

DIMENSIONS	A	B	C	D	E	F	G	H	I	øJ	K	L	M	N
DM 20/75	150	173	228	19	G 3/4"	84	R 1/4"	209	18	30	118	139	195	297
DM 25/125	200	202	302	27	G 1"	115	R 1/4"	279	18	30	160	164	195	351
DM 40/315	270	267	412	34	G 1 1/2"	100	R 1/2"	380	28	40	213	213	290	372
DM 50/565	350	345	538	48	G 2"	115	R 1/2"	493	30	60	286	285	404	573



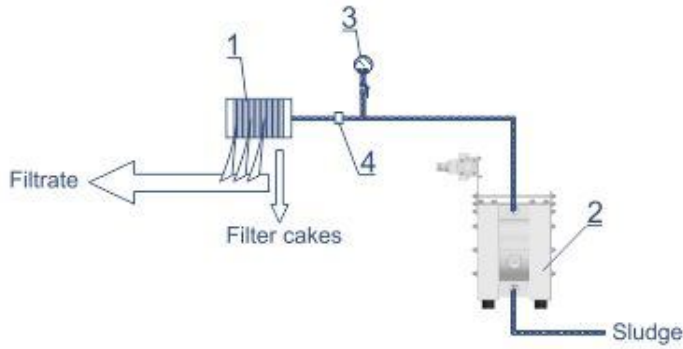

Part no.	Name
1	Filter press
2	Filling and pressure maintenance pump
3	Pressure gauge
4	Bursting disk

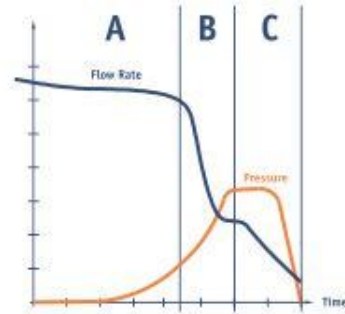

Typical operating cycle of filter press

- A – High capacity filling** allowing filter cake formation.
- B – End of filling**, filtration resistance, capacity reduction.
- C – Pressure maintenance**, filter cake formed, high filtration resistance,

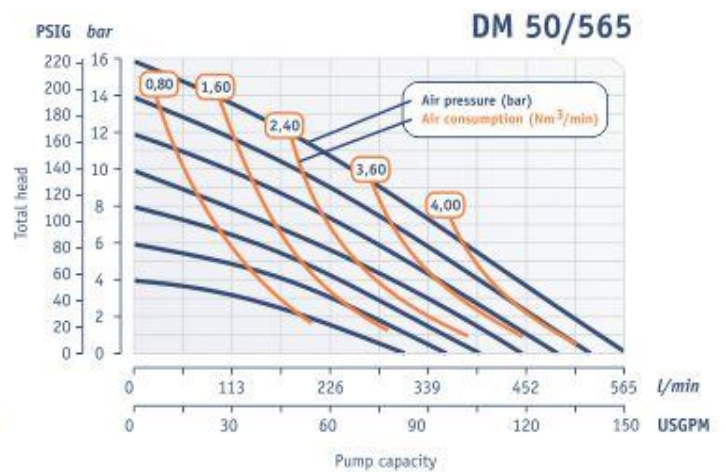
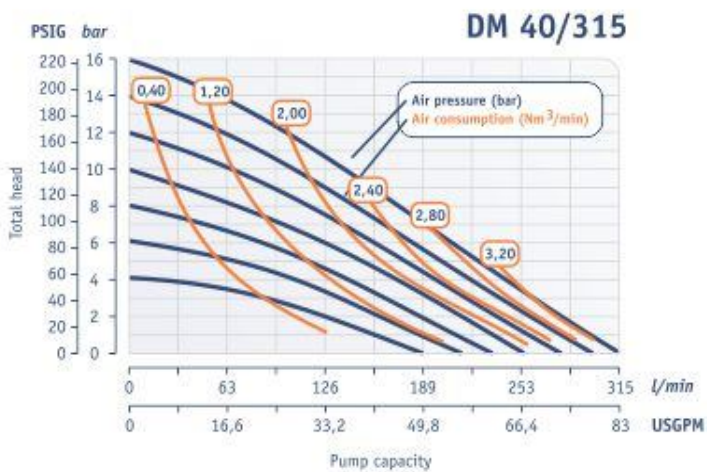
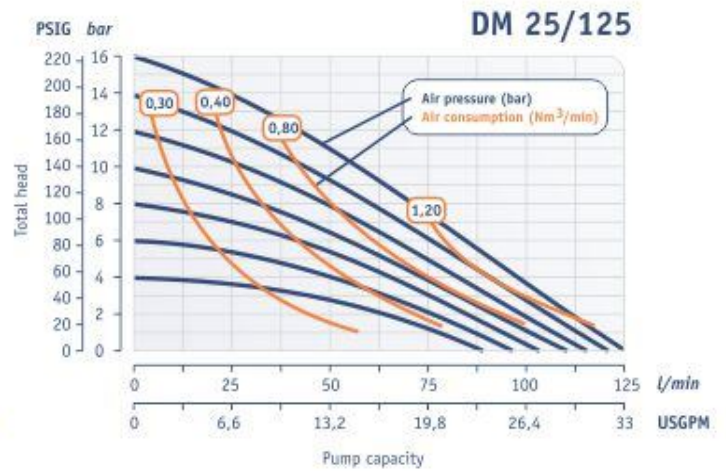

## HOW TO SELECT PUMPSIZE

Enter flow rate e.g. 75l/min and pressure 14 bar.  
A DM 25/125 will be suitable with 7 bar supplied compressed air.

## POWDER PUMPS



Dellmeco Pump can also transfer and handle dry process POWDERS more quickly, cleanly and at a fraction of the cost associated with installed systems.

### Features:

Replaces manual powder processes.

Reduces airborne contamination - transfer powder directly from the container to your recipe.

Economical and simple - unlike large, complex systems.

Portable - can be moved from site to site.

### For transferring POWDERS up to 800kg/m<sup>3</sup> (50lb/ft<sup>3</sup>)

For the consistent, trouble-free Powders transfer of:

- Ground limestone
- Pharmaceuticals
- Talcums
- Expanded mica
- Silicones
- Carbon black
- Fumed silica
- Acrylic resins



## PULSATION DAMPERS



An air cushion established by liquid pressure pushing the diaphragm upward. This allows air to enter the chamber. The balancing air cushion keeps the diaphragm center at mid stroke. During operation, the diaphragm flexes within the mid-range position, absorbing and equalizing discharge surge.

If pressure changes in the system, the air cushion pressure compensates automatical increasing or decreasing. If liquid pressure is released, air in the suppressor chamber exhausts into the atmosphere. Property sized and installed, dampers provide virtually surge-free discharge flow.



- Simple installation
- Virtually surge-free flows
- Less vibration and noise
- Steadier pressures
- Automatically self-charging and self-venting
- Variety of sizes and materials

### Example of the damper type code:

DM	15	P	E	P	
					<u>Material of damper head:</u> P - PE R - PE conductive
					<u>Diaphragm material:</u> E - EPDM T - TFM/PTFE N - NBR
					<u>Material of damper housing:</u> P - PE R - PE conductive A - Aluminium S - AISI 316 Industrial H - AISI 316L Hygienic T - PTFE Z - PTFE conductive
					<u>Size, nominal connection size:</u> 08: 3/8"; 10, 15: 1/2", 20: 3/4", 25: 1", 40: 1 1/2", 50: 2", 65: 2 1/2", 80: 3"

DELLMECO pulsation damper

Air supply connection: DM 08/10: R 1/8"  
DM 15/20/25: R 1/8"  
DM 40/50/65: R 1/4"  
DM 80: R 1/2"

Max. operating pressure: 8 bar  
Max. operating temperature: PE damper housing 70 °C ;  
PTFE damper housing 120 °C;  
Metal damper housing 120 °C

### Plastic dampers

For inflammable liquids as well as for applications in explosion protected areas, only dampers made of conductive polymer materials (code Z resp. R) may be used. It is not necessary to ground the damper separately, as the damper is connected conductively to the pump, which is conductive and has to be grounded itself.

In general, pump and damper are dispatched completely mounted. Still, they can be packed in separate boxes, for client wish. If so, the damper has to be screwed into the thread at the top of discharge port carefully, but only until the damper is in contact with the pump. Exceeded tightening may damage the thread. Besides, a correct positioning of the O-ring within the groove has to be ensured.

### Metal dampers

For inflammable liquids as well as for applications in explosion protected areas, only dampers made of PE conductive (code R) may be used. It is necessary to ground the damper separately, as the damper is not connected to the pump, which is conductive and has to be grounded itself. In general, pump and damper are dispatched separately.



## PLASTIC DAMPERS INTEGRATED WITH PUMPS



### DIMENSIONAL DRAWING

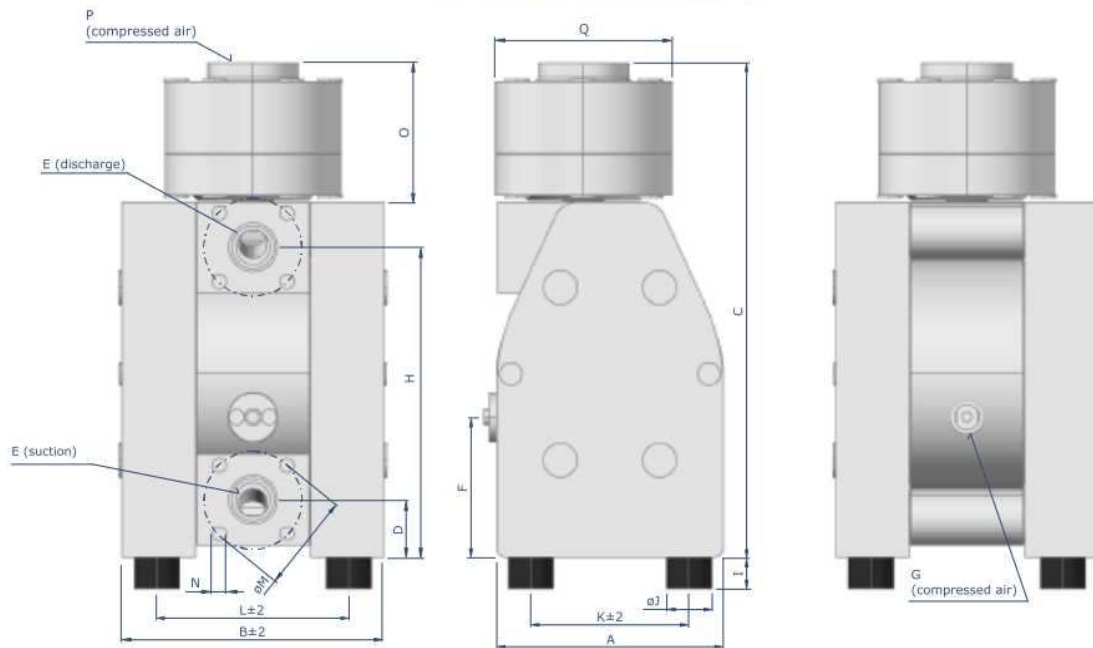

DIMENSIONS	A	B	C	D	E	F	G	H	I	ØJ	K	L	M	N	O	P	Q
DM 08/10	70	111	193	15	G 1/4"	58	R 1/8"	107	10	15	50	86	-	-	74	R 1/8"	73
DM 10/25	105	128	238	18	G 3/8"	84	R 1/8"	150	10	15	75	93	-	-	81	R 1/8"	104
DM 15/55	153	177	325	40	G 1/2"	87	R 1/4"	202	18	30	112	136	65	M12	81	R 1/8"	104
DM 25/125	200	232	435	50	G 1"	123	R 1/4"	272	28	40	140	170	85	M12	119	R 1/8"	156
DM 40/315	270	312	581	57	G 1 1/2"	109	R 1/2"	373	30	60	190	227	110	M16	151	R 1/4"	204
DM 50/565	350	385	726	52	G 2"	158	R 1/2"	478	30	60	270	282	125	M16	183	R 1/4"	273
DM 80/800	480	580	800	100	G 3"	388	R 3/4"	690	40	75	395	495	160	M16	261	R 1/2"	360

## METAL

Material	Aluminium					
Type	DM 15	DM 20	DM 25	DM 40	DM 50	DM 80
A	99	99	139	170	215	282
ØB	108	108	156	204	273	360
C	G 1/2"	G 3/4"	G 1"	G 1 1/2"	G 2"	G 3"
D	12	15	20	19	32	30
E	R 1/8"	R 1/8"	R 1/8"	R 1/4"	R 1/4"	R 1/2"

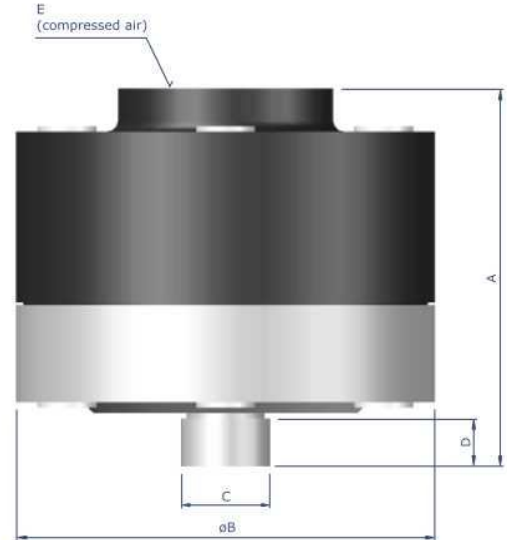

Material	AISI 316L (for Industrial series)			
Type	DM 20	DM 25	DM 40	DM 50
A	141	141	171	230
ØB	150	150	204	273
C	G 3/4"	G 1"	G 1 1/2"	G 2"
D	18	18	20	32
E	R 1/8"	R 1/8"	R 1/4"	R 1/4"

## HYGIENIC AISI 316L - POLISHED

AISI 316L						
Type	DM 15	DM 25	DM 40	DM 50	DM 65	
A	104	149	148	178	220	
ØB	104	150	156	204	273	
C	80	123	123	150	198	
D	TC	1/2"	1"	1 1/2"	2"	2 1/2"
	DIN	15	25	40	50	65
	SMS	-	25.00	38.00	51.00	63.50
E	R 1/8"	R 1/8"	R 1/8"	R 1/4"	R 1/4"	

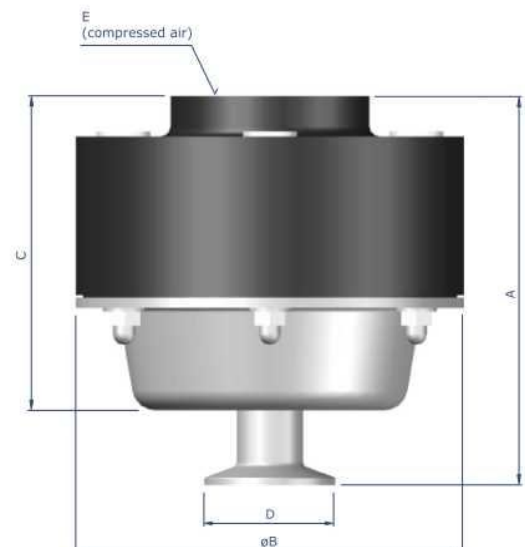



## STANDARD BSP



Standard connection for all plastic and metal pumps.

## FLANGE CONNECTIONS PN10



This version offers the possibility to use flange connectors according to DIN/PN 10. Thread bushings made of stainless steel to fix the flangers are included in the inlet/outlet. The O-rings attached have to be inserted into the grooves of the manifolds to improve sealing before connecting the pump.

- F1 - Flange connection PN 10 EPDM
- F2 - Flange connection PN 10 NBR
- F3 - Flange connection PN 10 FEP/FPM

## FLANGE CONNECTIONS



F7 - PN10 DIN 2576  
F8 - ANSI 150 RF-SO  
F9 - PN16 DIN 2277/2278

## S - SPLIT CONNECTIONS



All pump models can have Split Connections - code S. Pump can be converted from a double-acting air-driven diaphragm pump into two separated single-acting ones. The standard sleeve with one suction and one discharge connection is exchanged for a sleeve with split connections, so with separate suction and discharge connections for both pump chambers. By separation in two pump halves with the same drive, there are two liquid streams in 1:1 ratio.

Other connections on request.



## BARRIER CHAMBER SYSTEM



To comply with high safety standards, the barrier chamber system replaces the standard diaphragm by a tandem arrangement of two diaphragms and a barrier chamber of conductive PE filled with a non-conductive liquid in between.

Conductivity sensors monitor the conductivity of this fluid.

If the diaphragm fails, the sensors detect a conductivity variance and signal is sent to a controller.

The barrier system is available in three variations:

- BC1 barrier system with sensors, standard
- BC2 barrier system complete with sensors and controllers
- BC3 barrier system complete with sensors and controllers for explosion-proof zone - ATEX

### MAIN DIMENSIONS

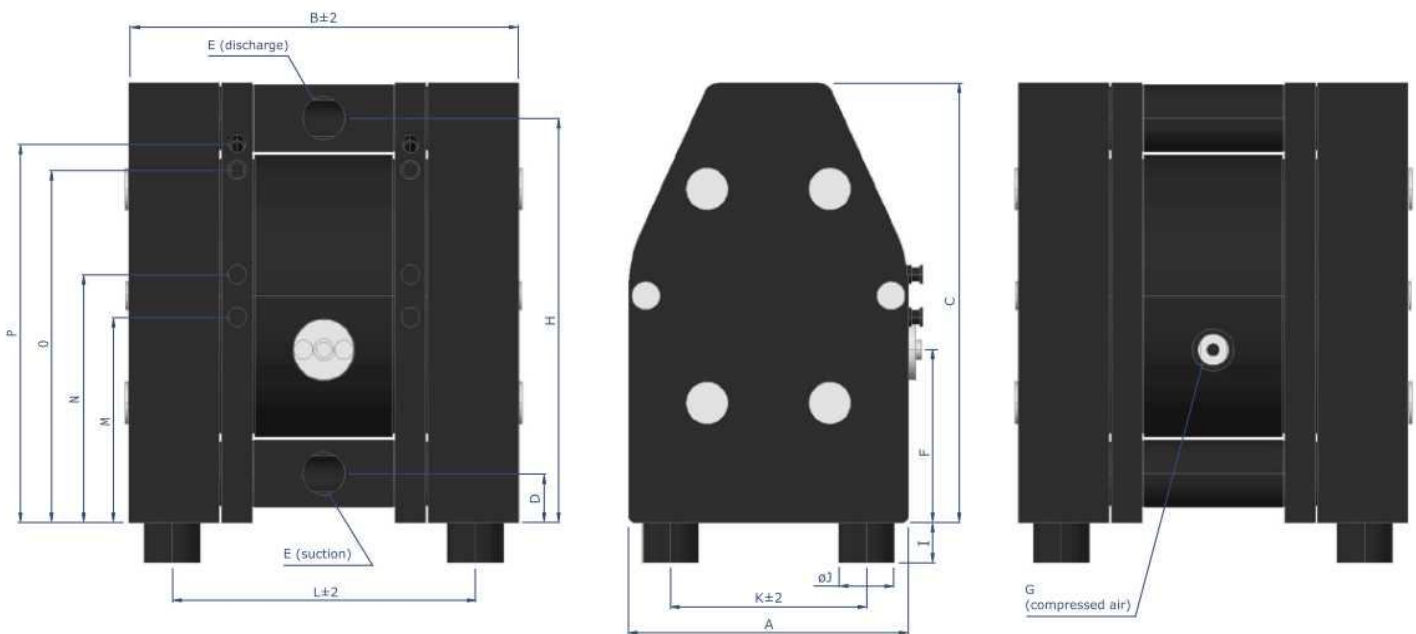

DIMENSIONS	A	B	C	D	E	F	G	H	I	øJ	K	L	M	N	O	P
DM 10/25	105	173	164	18	G 3/8"	84	R 1/8"	150	10	15	75	138	61	84	128	146
DM 15/55	153	223	235	25	G 1/2"	87	R 1/4"	217	18	30	112	182	86	111	191	209
DM 25/125	200	282	312	35	G 1"	123	R 1/4"	287	28	40	140	220	146	176	250	270
DM 40/315	270	360	426	42	G 1 1/2"	109	R 1/2"	388	30	60	190	276	204	229	349	369
DM 50/565	350	433	540	45	G 2"	158	R 1/2"	485	30	60	270	335	253	278	443	463

## STROKE COUNTING



### STROKE COUNTING (OPTION CODE SC1, SC2, SC3, SC5, SC6)

A sensor is installed in the central pump housing to count the strokes. The diaphragm movement is scanned without contact by this sensor - a safe form of monitoring totally independent of external influences and the pump's mode of operation. The issued sensor pulses can be sent as output data to existing detectors or to a stroke counter (can also be supplied). When the preset value is reached, the stroke counter sends an output signal which can then be processed further, for instance in order to shut down the pump via a solenoid valve.

The stroke counting system is available in five variations:

- SC 1 Stroke sensor (Namur), also for explosion-proof zone
- SC 2 Stroke counting system complete with sensor and stroke counter
- SC 3 Stroke counting system complete with sensor, stroke counter and controller for explosion-proof zone
- SC 5 Stroke counting pneumatical with pressure transmitter
- SC 6 Stroke counting as SC5 but cpl. with stroke counter

In case only the sensor is included (code SC1), it has to be connected to an existing controller with Namur inlet. For explosion-proof applications, stroke counting option requires an intrinsically safe controller (code SC3), which has to be installed between sensor and counter. The wiring diagram and technical data can be found on the electric units themselves. For further details, please refer to the data delivered by the manufacturers of the components. The controllers have to be installed in a suitable cabinet.



## DIAPHRAGM MONITORING



Although DELLMECO diaphragms with integrated metal core are designed for an optimum service life, the diaphragm remains a wear part. If it breaks, liquid can leak into the center housing and possibly emerge through the muffler. This can be prevented simply and effectively with the DELLMECO diaphragm monitoring.

A capacitive diaphragm sensor is mounted in the muffler of the pump, which registers any liquid approaching the sensor, no matter whether the liquid is conductive or not. Hence, a fast reaction to a damage of a diaphragm becomes possible. In case of humid surrounding air a false alert may occur despite operating the pump with dried compressed air.

The diaphragm monitoring system is available in two variations:

- DM1 Diaphragm sensor (Namur), also for explosion proof area
- DM2 Diaphragm monitoring system complete with sensor and controller

## BACK FLUSHING



### BACK FLUSHING SYSTEM (OPTION CODE BF1, BF2, BF3, BF4, BF5)

The pump equipped with the back flushing system (ball lift system) can be emptied along with an including discharge line while being installed within the plant. It consists of a bypass-system in the side housings which can be activated by manual valves (code BF1, BF2, BF3) or pneumatically (code BF4, BF5).

Open the manual valves (BF1, BF2) by approx. 10 mm turning it to the left (attention: as there is no blocking of the valves, it has to be ensured not to take them out completely). The pump should be kept in operation meanwhile. Slow down the pump by decreasing air inlet pressure and finally stop it.



Illustration on the left presents pneumatically activated back flushing system (code BF4 and BF5, minimum air pressure: 3 bar). By attaching a 4-2-way valve (not included in the delivery), the back flushing system can be activated automatically when cutting off the pump.

The O-rings side housing are made of EPDM (BF1, BF4), PTFE (BF2, BF5) or resp. FPM (BF3).



Ball lifters for metal pumps (BF2 option).



## PNEUMIXERS



### How it functions...

The Pneumixer works both as product transport pump as well as mixer. It utilizes the container the product arrives in to mix and dispense. The Pneumixer simply fits securely in the vessels fill hole. With this ingenious system there is no need of rolling, shaking or pumping to a mixing vessel that adds time, waste, mess and expense.

Available in stainless steel AISI 316L.

### Mixing mode

The discharge valve is closed and the recirculation valve is open to allow the product to circulate in container.

### Transfer mode

The discharge valve is open and recirculation valve is partially open, to both mix and to transfer the product out of Pneumixer.



## DRUM PUMPS



DELLMECO drum pumps are available in the following materials: PE, PTFE (also conductive), aluminium and AISI 316L for optimum fluid compatibility. They can work with liquids with different viscosities; available up to 1".

Converting 3/8", 1/2", 3/4" or 1" plastic or metal pumps to a drum or pail application is easy. The adaptor kits are constructed of chemically - resistant materials to handle the job. Plastic or metal pipe assembly comes complete with all the hardware needed. Simply attach the adaptor to the drum and place the pump with tube into it.

The standard length of tubes are: 1 m or 1,2 m.

## INSTALLATION

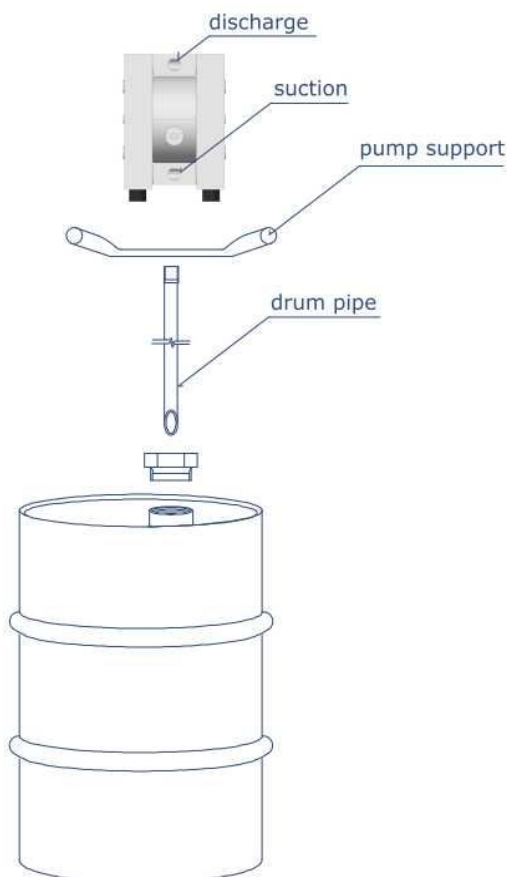

### Material of tubes:

- Polypropylene,
- PTFE,
- Aluminium,
- AISI 316



## F-SERIES DIAPHRAGM PUMP



F-series are pneumatic diaphragm pumps with integrated pulsation damper and two separated product chambers. Transport of liquid is realized by the delivery chamber. The fluid passes an active pulsation damper to smoothen the flow. Trouble-free operation of the pulsation damper is only possible with a minimum back pressure of 1 bar and becomes increasingly efficient as the back pressure increases.

The second product chamber can be used as an extractor, then not needed e.g. ink or glue can be sucked from the machine back to the supply container. Another possibility is to use the second chamber as circulation pump, then we have the ink circulated within the supply container. Circulating ink helps to ensure complete blending and to avoid sedimentation.

Pneumatic diaphragm pump of the F-Series with the housing material PE-conductive may be used for inflammable liquids as well as for applications in explosion-proof areas.

## PUMP WITH SOLENOID VALVE - MV OPTION



DELLMECO Plastic pumps with MV option use electrical impulses to stroke the pump instead of differential pressure, as in standard pumps equipped with air distributor.

The solenoid air valve is a 2-position, 4-way solenoid valve. When the solenoid is unpowered, one air chamber within the pump is pressurized with air, while the opposite chamber is exhausted. When electric power is applied, the solenoid shifts and pressurizes the exhausted chamber, while the opposite pressurized chamber is being exhausted.

By alternately applying and removing power, pump with MV option runs like a standard DELLMECO Pump, with no lubrication needed.

This option needs 24 V DC operation.

Pumps with MV option are not submersible.



## SEMI - ULTRA HIGH PURITY CHEMICAL PUMPS FOR SEMICONDUCTOR INDUSTRY



### GENERAL INFORMATION

The pumps from SEMI DMS series have been designed especially for the purpose of semiconductor industry. The whole assembly process of these unique products is completed in a **CLASS 100 CLEAN ROOM**, involving a double cleaning of the parts, their testing with deionized water, and finally sealing in plastic foils.

All parts of the SEMI T and SEMI H pumps coming in touch with liquids are made of PTFE and TFM. The housing parts of the SEMI E pump coming in contact with liquids are made of UPPE (ultra pure polyethylene). Therefore it must be checked that any liquid to be used in the pump comply with the construction materials.

In case of the SEMI E pump, it is an absolute must to obey the limits set to operating pressure (max. 6 bar) and the temperature of a liquid (max. 70°C). In case of the SEMI H, T and S pumps, the temperature limits and dependable driving pressure are different. The chart below presents maximum permissible values.

Driving air pressure	6 bar	5 bar	4 bar	3 bar	2 bar
SEMI T : max. permissible temperature	100°C	110°C	120°C	130°C	130°C
SEMI H : max. permissible temperature	100°C	130°C	150°C	180°C	200°C
SEMI E : max. permissible temperature	70°C	70°C	70°C	70°C	70°C
SEMI S : max. permissible temperature	130°C	130°C	130°C	130°C	130°C

### FEATURES

- no metal parts at all
- no elastomer o-ring seals
- no lubrication in air valve
- class 100 clean-room assembled, tested with de-ionized water and double packaged
- TFM diaphragms for extended flex life
- four materials for different applications with max temp. 200°C
- machined from solid material on a very highly advanced CNC Machining and Turning Centre
- pulsation dampers, leak detection, electronic/pneumatic controls and monitoring available for all sizes
- very easy repairing, just 40% spares comparing to other competitors!

### SEMI PUMPS SUMMARY

<i>Model:</i>	<b>SEMI T</b>
<i>Materials:</i>	center housing TFM/PTFE; side housings UPPE
<i>Pump sizes:</i>	10, 20, 50, 100
<i>Products:</i>	acids and caustics
<i>Model:</i>	<b>SEMI H</b>
<i>Materials:</i>	center housing TFM/PTFE; side housings PTFE
<i>Pump sizes:</i>	10, 20
<i>Products:</i>	hot applications with acids and caustics
<i>Model:</i>	<b>Semi E</b>
<i>Materials:</i>	center housing UPPE; side housings UPPE
<i>Pump sizes:</i>	10, 20, 50, 100
<i>Products:</i>	slurries
<i>Model:</i>	<b>SEMI S</b>
<i>Materials:</i>	center housing SS 316 L; side housings SS 316 L
<i>Pump sizes:</i>	20, 50
<i>Products:</i>	solvents



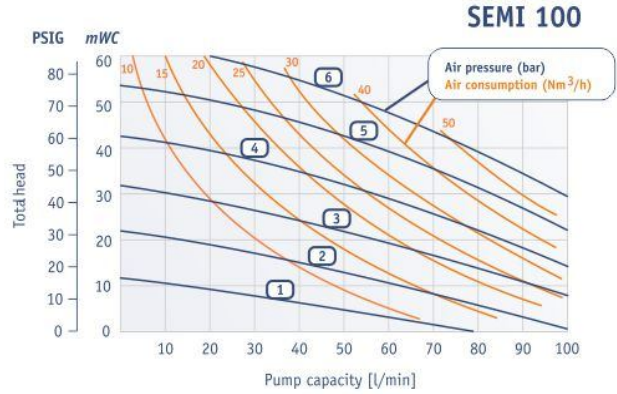
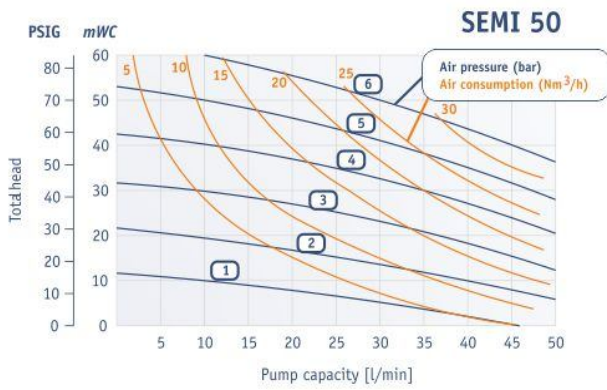
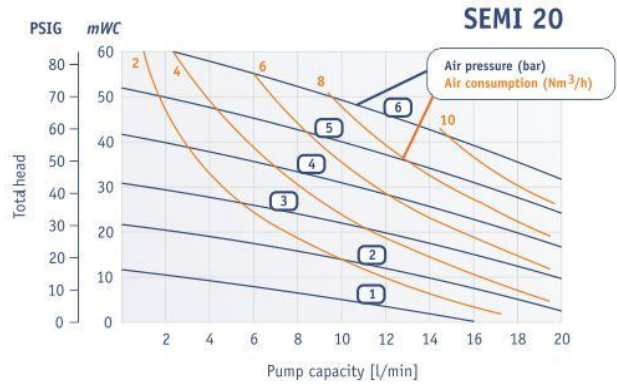
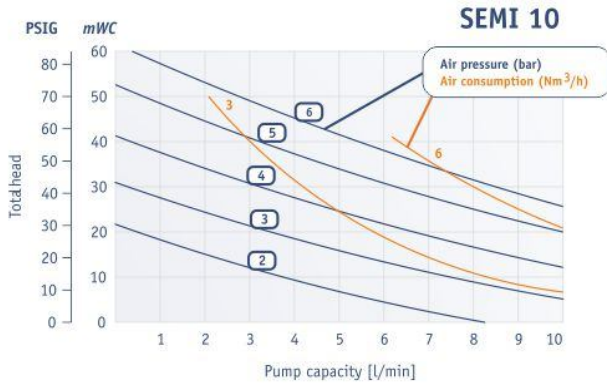

**MAIN DIMENSIONS**

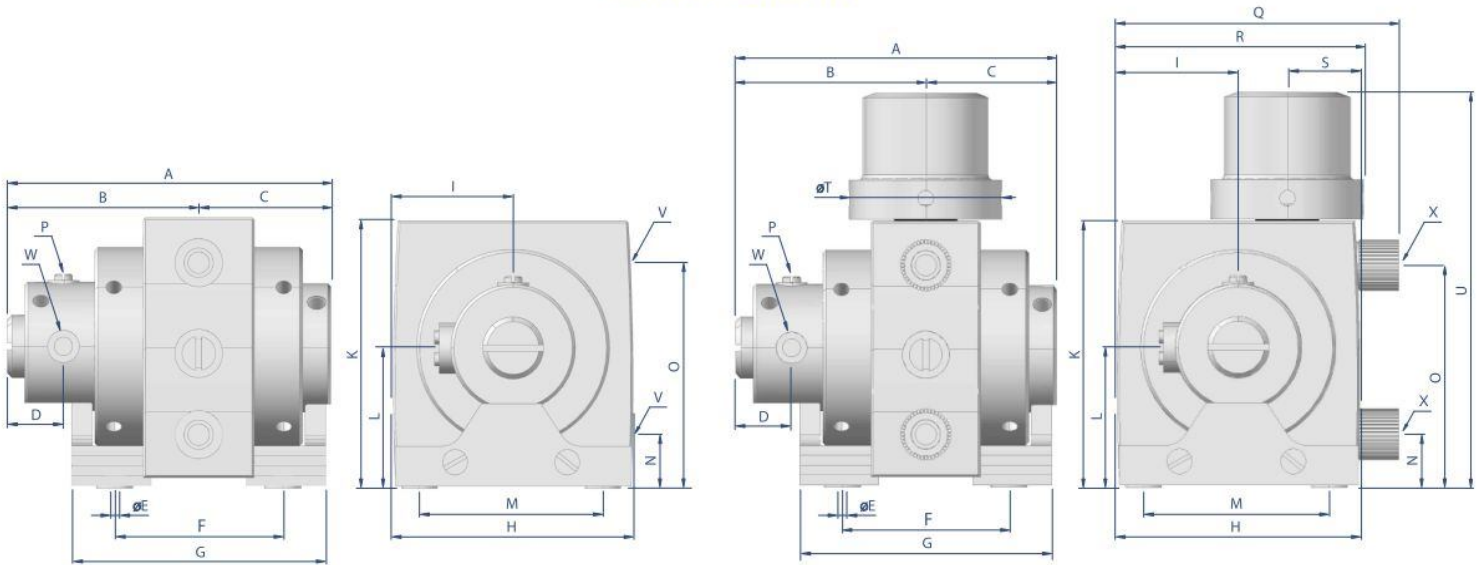

mm	A	B	C	D	E	F	G	H	I	K	L	M	N	O	Q	R	S	T	U	V	W	X
<b>SEMI 10</b>	184,0	112,0	72,0	28,0	10,5	95,0	145,0	114,0	57,0	133,0	68,0	79,5	37,0	105,0	155,0	155,0	36,0	110,0	245,0	3/8" NPT	1/4" NPT	3/8"
<b>SEMI 20</b>	207,0	109,0	98,0	35,0	10,5	109,0	163,0	154,0	75,0	172,0	91,0	115,0	32,0	139,0	200,0	163,0	46,0	110,0	287,0	1/2" NPT	1/4" NPT	1/2"
<b>SEMI 50</b>	255,0	157,0	98,0	46,0	19,0	113,0	195,0	207,0	104,0	215,0	110,0	165,0	33,0	177,0	258,0	224,0	59,0	150,0	346,0	1" NPT	1/4" NPT	1"
<b>SEMI 100</b>	315,0	196,0	119,0	57,0	19,0	138,0	238,0	269,0	135,0	267,0	138,0	225,0	39,0	223,0	322,0	298,0	80,0	213,0	428,0	1 1/4" NPT	1/4" NPT	1 1/4"

in	A	B	C	D	E	F	G	H	I	K	L	M	N	O	Q	R	S	T	U	V	W	X
<b>SEMI 10</b>	7,2	4,4	2,8	1,1	0,4	3,7	5,7	4,5	2,2	5,2	2,7	3,1	1,5	4,1	6,1	6,1	1,4	4,3	9,6	3/8" NPT	1/4" NPT	3/8"
<b>SEMI 20</b>	8,1	4,3	3,9	1,4	0,4	4,3	6,4	6,1	3,0	6,8	3,6	4,5	1,3	5,5	7,9	6,4	1,8	4,3	11,3	1/2" NPT	1/4" NPT	1/2"
<b>SEMI 50</b>	10,0	6,2	3,9	1,8	0,7	4,4	7,7	8,1	4,1	8,5	4,3	6,5	1,3	7,0	10,2	8,8	2,3	5,9	13,6	1" NPT	1/4" NPT	1"
<b>SEMI 100</b>	12,4	7,7	4,7	2,2	0,7	5,4	9,4	10,6	5,3	10,5	5,4	8,9	1,5	8,8	12,7	11,7	3,1	8,4	16,9	1" NPT	1/4" NPT	1 1/4"

W - air supply P = 1/4" NPT air supply for pneumatic stroke counting X = pipe-outer diameter special equipment FLARETEK®





DELLMECO LTD  
Unit 1, Willow Row  
Longton  
Stoke On Trent  
Staffordshire  
ST3 2PU  
United Kingdom  
tel. +44 1782 793 029  
fax: +44 1782 501 021  
  
sales@dellmeco.com  
www.dellmeco.com

