

For immersion depths  
up to 3 m

# Submersible centrifugal pump ZAT

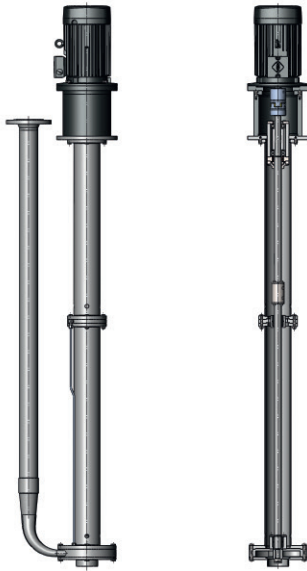

## Features:

- Up to a maximum depth of 3 m,
- All wetted parts are electropolished,
- Robust construction made of chrome-nickel-molybdenum stainless steel 1.4435 (316L),
- Gentle pumping of sensitive liquids,
- CIP capability,
- Variety of application areas.

## Applications:

- Salt water, sugar solutions,
- Chemicals,
- Solvents,
- Textile wastewater with fiber and yarn shares (no clogging),
- Contaminated wastewater,
- For use in neutralization plants.

Flow rate Q [m <sup>3</sup> /h]	max. 70
Delivery head H [m]	up to 60
Temperature range [°C]	minus 30 to 80
Viscosity [mPa s]	up to max. 500

