

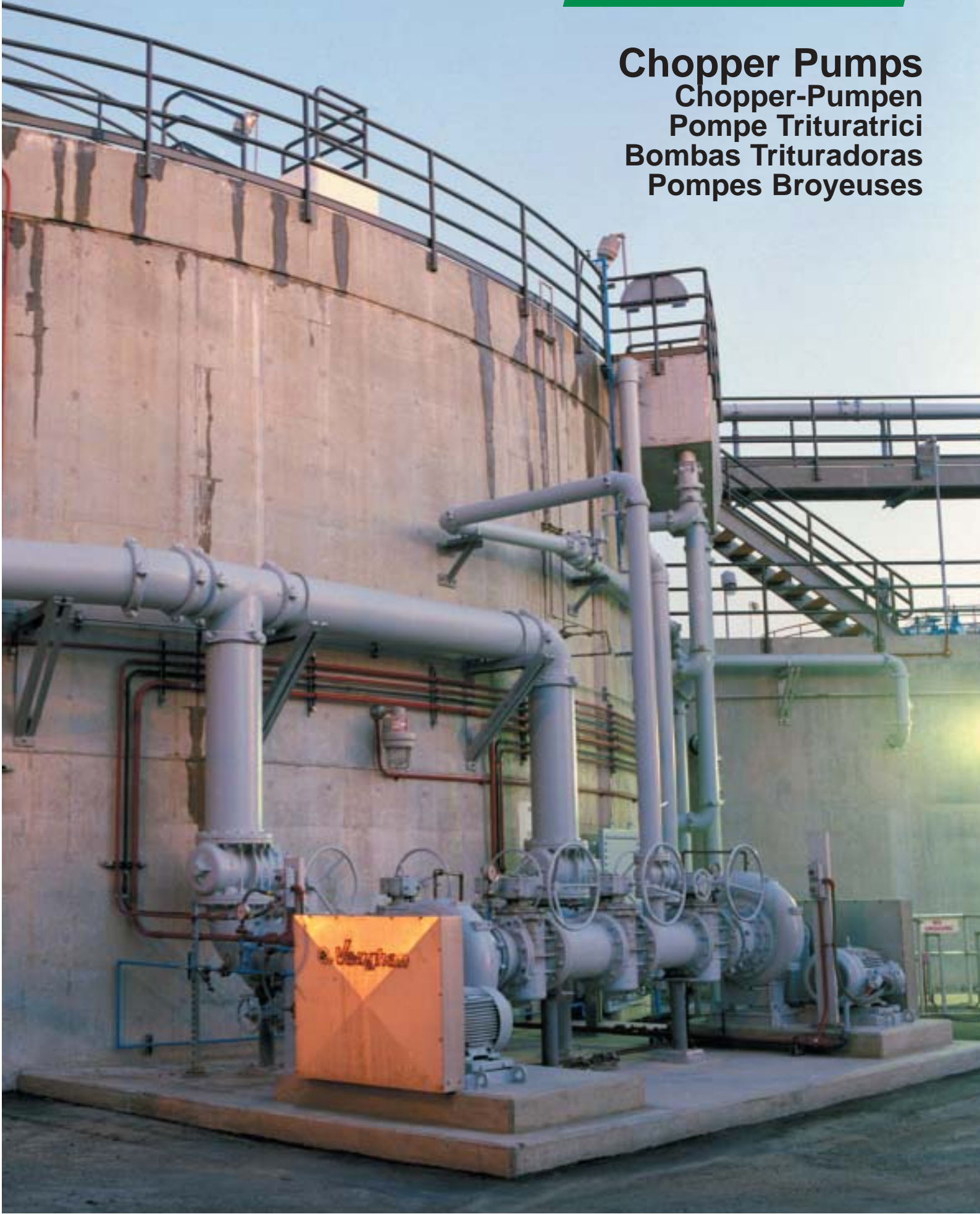

Vaughan

Chopper Pumps
Chopper-Pumpen
Pompe Trituratrici
Bombas Trituradoras
Pompes Broyeuses





Vaughan

40 Years of Experience
40 Jahre Erfahrung
40 anni di esperienza
40 años de experiencia
40 années d'expérience

Reliability
Zuverlässigkeit
Affidabilità
Fiabilidad
Fiabilité



Vaughan's written guarantee is your assurance of clog-free solids-handling performance.

Die schriftliche Garantie von Vaughan gibt Ihnen die Gewissheit einer verstopfungsfreien Förderung.

La garanzia scritta della Vaughan assicura una triturazione dei solidi senza intasamenti.

La garantía por escrito de Vaughan es su compromiso de funcionamiento de bombas de manejo de sólidos sin atascos.

La garantie écrite de Vaughan est votre assurance d'un transfert de solides sans bouchage.



How Vaughan Chopper Pumps Work

So funktionieren die Vaughan Chopper-Pumpen

Come funzionano le pompe trituratrici Vaughan

Cómo funcionan las bombas trituradoras de Vaughan

Comment fonctionnent les pompes broyeuses Vaughan

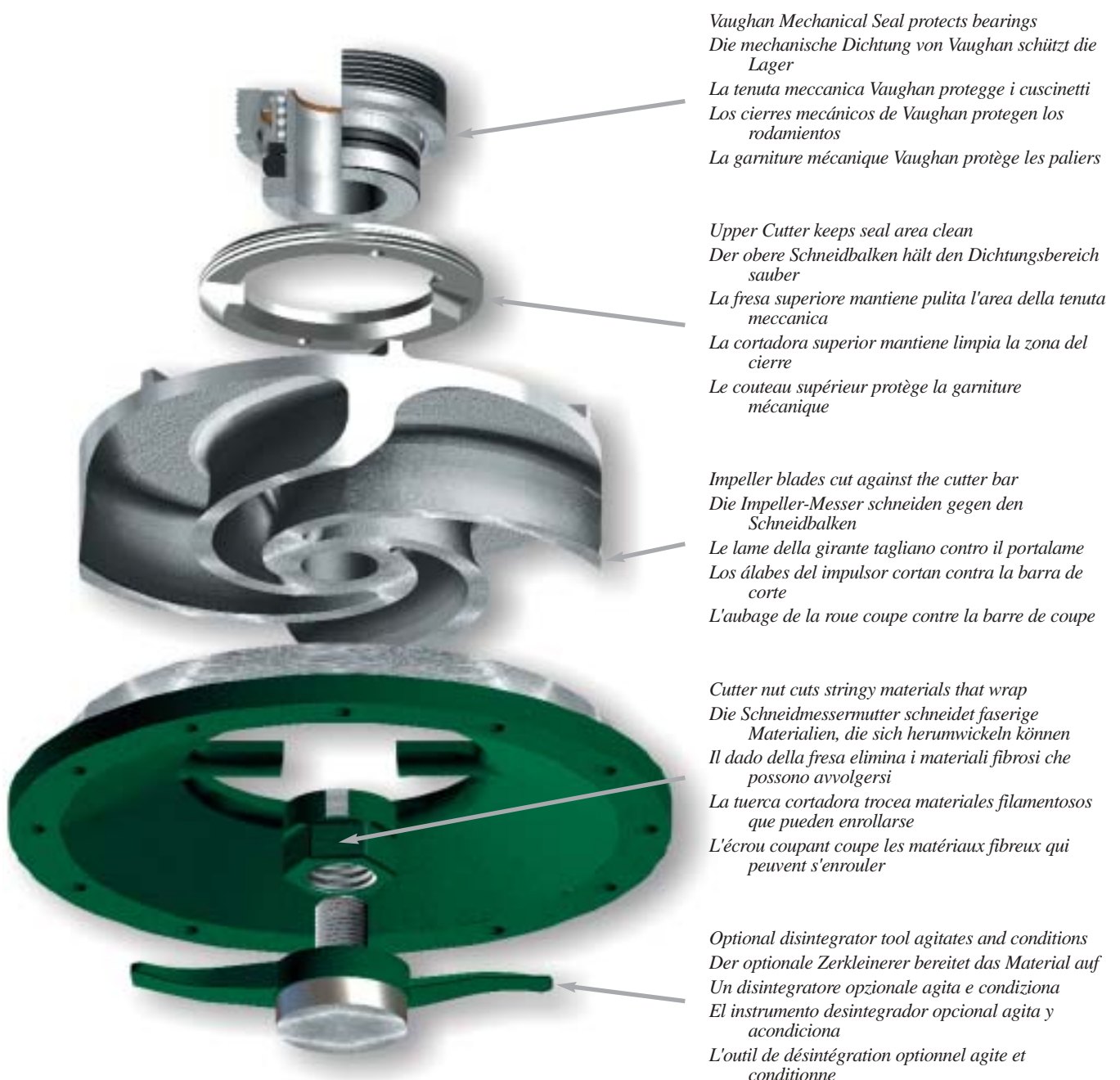

Vaughan Mechanical Seal protects bearings
Die mechanische Dichtung von Vaughan schützt die Lager

La tenuta meccanica Vaughan protegge i cuscinetti
Los cierres mecánicos de Vaughan protegen los rodamientos

La garniture mécanique Vaughan protège les paliers

Upper Cutter keeps seal area clean
Der obere Schneidbalken hält den Dichtungsbereich sauber

La fresa superiore mantiene pulita l'area della tenuta meccanica

La cortadora superior mantiene limpia la zona del cierre

Le couteau supérieur protège la garniture mécanique

Impeller blades cut against the cutter bar
Die Impeller-Messer schneiden gegen den Schneidbalken

Le lame della girante tagliano contro il portalamo
Los álabes del impulsor cortan contra la barra de corte

L'aubage de la roue coupe contre la barre de coupe

Cutter nut cuts stringy materials that wrap
Die Schneidmessermutter schneidet faserige Materialien, die sich herumwickeln können
Il dado della fresa elimina i materiali fibrosi che possono avvolgersi

La tuerca cortadora trocea materiales filamentosos que pueden enrollarse

L'écrou coupant coupe les matériaux fibreux qui peuvent s'enrouler

Optional disintegrator tool agitates and conditions
Der optionale Zerkleinerer bereitet das Material auf
Un disintegratore opzionale agita e condiziona
El instrumento desintegrador opcional agita y acondiciona

L'outil de désintégration optionnel agite et conditionne



Vaughan

Products Produkte Produits Prodotti Productos



Vertical Wet Well
Vertikal-Pumpe in
Nassaufstellung
Verticali a cassa bagnata
Pozo húmedo vertical
Verticale



Cantilever
Ausleger-Pumpe
Tipo a sbalzo
Cantilever
Cantilever



Electric Submersible
Elektrische Tauchpumpe
Elettriche immergibili
Sumergible eléctrico
Submersible électrique



Hydraulic Submersible
Hydraulische Tauchpumpe
Idrauliche immergibili
Sumergible hidráulico
Submersible hydraulique

Horizontal
Horizontal-Pumpe
Orizzontali
Horizontal
Horizontale



Vertical Dry Pit
Vertikal-Pumpe in
Trockenaufstellung
Verticali a cassa asciutta
Pozo seco vertical
Verticale en fosse sèche



Vertical Recirculator
Vertikal-Rezirkulationspumpe
Verticali di ricircolo
Recirculador vertical
Verticale avec recirculation



Self Primer
Selbstansaugend
Autoadescanti
Autoaspirante
Auto-amorçante

“E” Series 50 Hertz Performance Map
50-Hertz-Leistungsdigramm, Serie E
Copertura delle prestazioni Serie “E” 50 Hertz
Cobertura de funcionamiento de la serie E a 50 hertzios
Tableau de performance à 50 Hz pour la série E

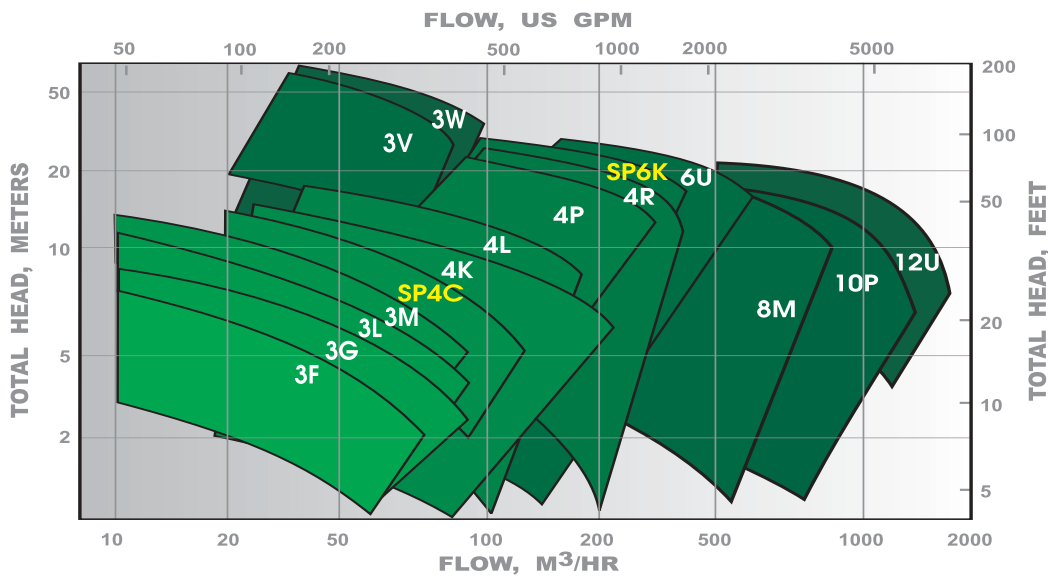

“E” Series 60 Hertz Performance Map
60-Hertz-Leistungsdigramm, Serie E
Copertura delle prestazioni Serie “E” 60 Hertz
Cobertura de funcionamiento de la serie E a 60 hertzios
Tableau de performance à 60 Hz pour la série E

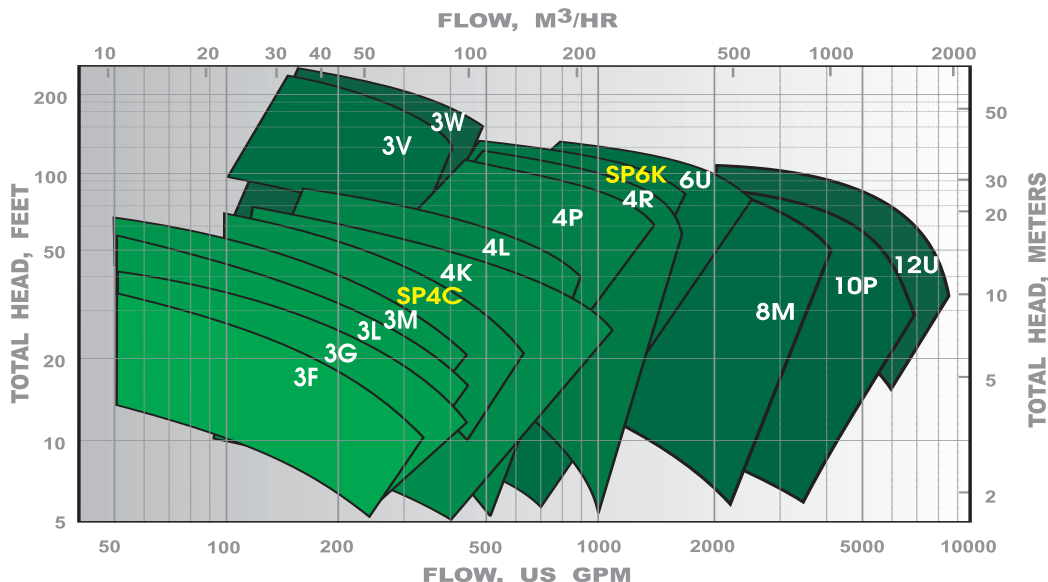



Vaughan

Vertical Wet Well
Vertikale Nassaufstellung
Verticali a cassa bagnata
Pozo húmedo vertical
Verticale à ligne d'arbre

Wet Wells
Nassaufstellung
Cassa bagnata
Pozos húmedos
Pompes verticales



OIL FILLED HOUSING
 ÖLGEFÜLLTER BEHÄLTER
 SCATOLA CUSCINETTI RIEMPITA DI OLIO
 ALOJAMIENTO LLENO DE ACEITE
 CARTER EMPLI D'HUILE

THRUST BEARINGS
 DRUCKLAGER
 CUSCINETTI REGGISPINTA
 COJINETES DE IMPULSO
 PALIERS DE BUTÉE

MECHANICAL SEAL
 MECHANISCHE
 DICHTUNG
 TENUTA
 MECCANICA
 CIERRE MECÁNICO
 GARNITURE
 MÉCANIQUE

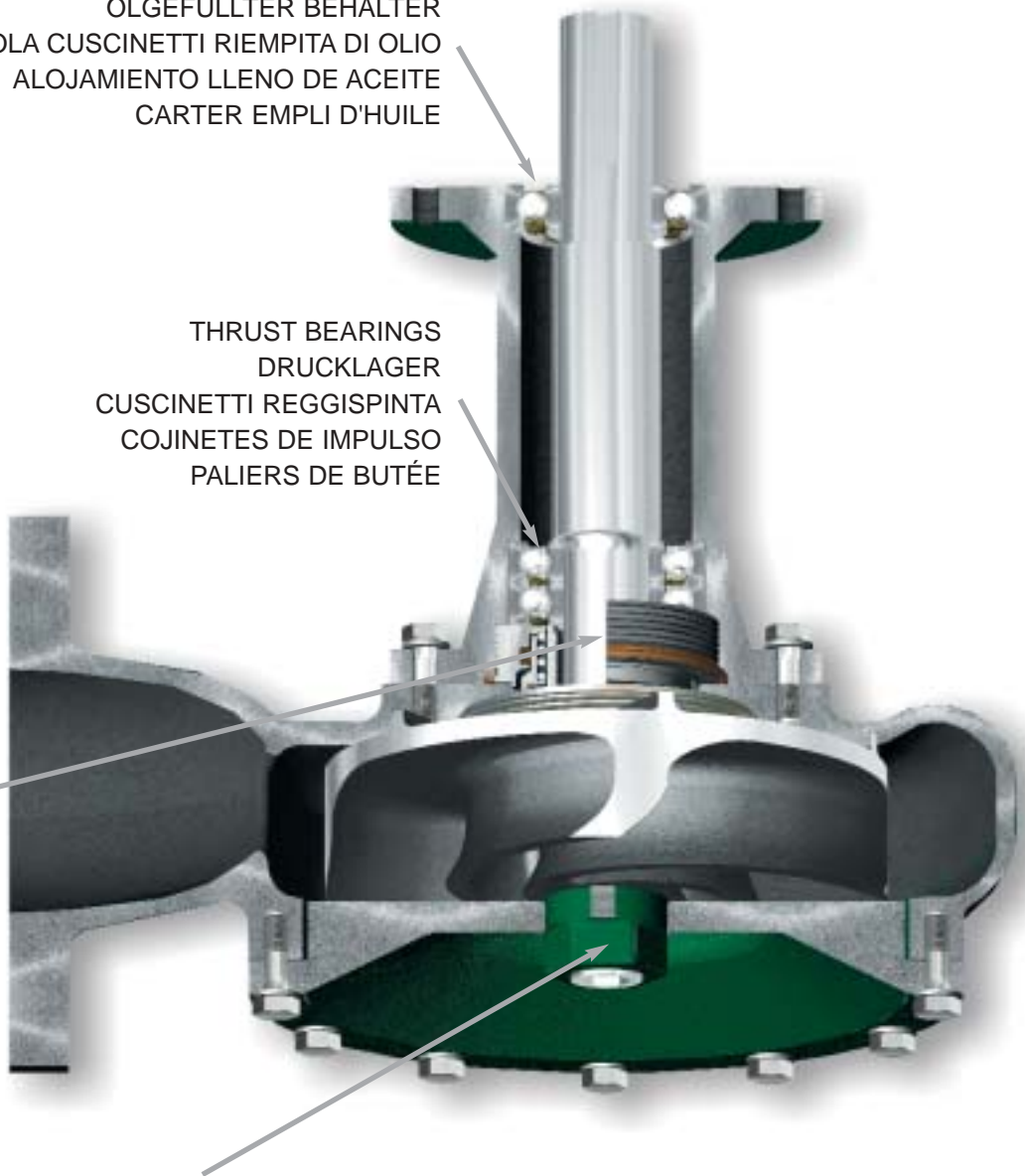

CHOPPER IMPELLER, CUTTER BAR, UPPER CUTTER AND CUTTER NUT
 CHOPPER-IMPELLER, SCHNEIDBALKEN, OBERES SCHNEIDMESSER UND SCHNEIDMUTTER
 GIRANTE TRITURATRICE, PORTALAME, FRESA SUPERIORE E DADO FRESA
 IMPULSOR TRITURADOR, BARRA DE CORTE, CORTADORA SUPERIOR y TUERCA DE CORTE
 AUBES BROYEUSES, BARRE DE COUPE, COUPEAU SUPÉRIEUR ET ÉCROU COUPANT

**Cantilever
Ausleger-Pumpe
A Sbalzo
Cantilever
Cantilever**



ROLLER AND BALL BEARINGS
ROLLEN- UND KUGELLAGER
CUSCINETTI A SFERA E A RULLO
COJINETES DE RODILLOS Y DE BOLAS
ROULEMENTS À ROULEAUX ET
ROULEMENTS À BILLES

LARGE 100mm SHAFT
GROSSER 100-mm-SCHAFT
ALBERO DI 100mm DI LARGHEZZA
EJE GRANDE DE 100 mm DE DIÁMETRO
ARBRE DE 100 mm DE DIAMÈTRE

NO SUBMERGED SEAL OR BEARINGS
KEINE EINGETAUCHTE DICHTUNG ODER LAGER
TENUTE O CUSCINETTI NON IMMERSI
SELLO O COJINETES NO SUMERGIBLES
PAS DE GARNITURE MÉCANIQUE NI PALIER DE PIED

CHOPPER IMPELLER, CUTTER BAR AND CUTTER NUT
CHOPPER-IMPELLER, SCHNEIDBALKEN UND
SCHNEIDMUTTER
GIRANTE TRITURATRICE, PORTALAME E DADO FRESA
IMPULSOR TRITURADOR, BARRA DE CORTE y TUERCA
CORTADORA
AUBES BROYEUSES, BARRE DE COUPE ET ÉCROU
COUPANT

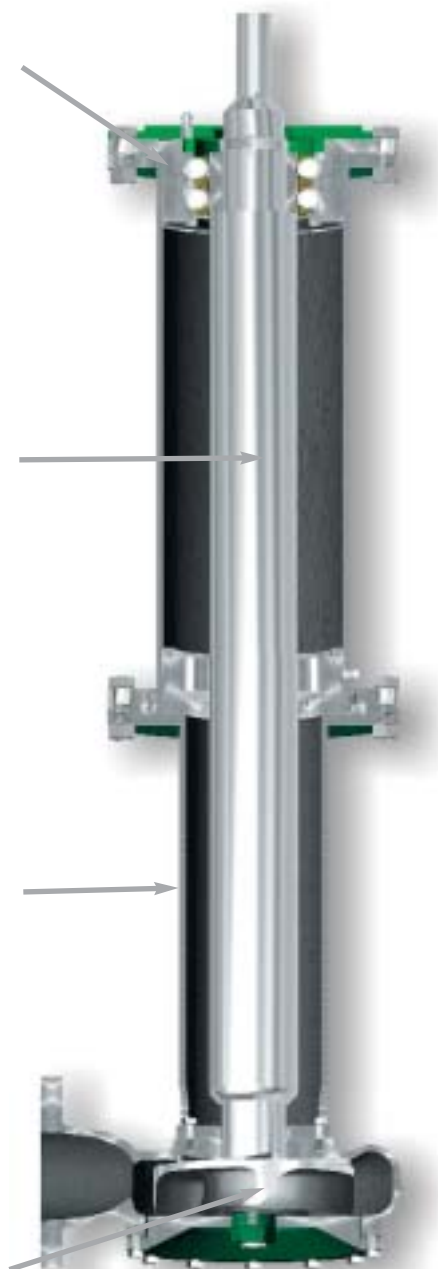



Vaughan

**Electric Submersible
Elektrische Tauchpumpe
Elettriche immergibili
Sumergible eléctrico
Submersible électrique**

Submersibles
Tauchpumpen
Immergibili
Sumergibles
Submersibles



MECHANICAL SEAL
MECHANISCHE DICHTUNG
TENUTA MECCANICA
CIERRE MECÁNICO
CARTER À DÉPOSE ARRIÈRE

CHOPPER IMPELLER, CUTTER BAR, UPPER
CUTTER AND CUTTER NUT

CHOPPER-IMPELLER, SCHNEIDBALKEN,
OBERES SCHNEIDMESSER UND
SCHNEIDMUTTER

GIRANTE TRITURATRICE, PORTALAME, FRESA
SUPERIORE E DADO FRESA

IMPULSOR TRITURADOR, BARRA DE CORTE,
CORTADORA SUPERIOR Y TUERCA DE
CORTE

AUBES BROYEUSES, BARRE DE COUPE,
COUTEAU SUPÉRIEUR ET ECROU COUPANT

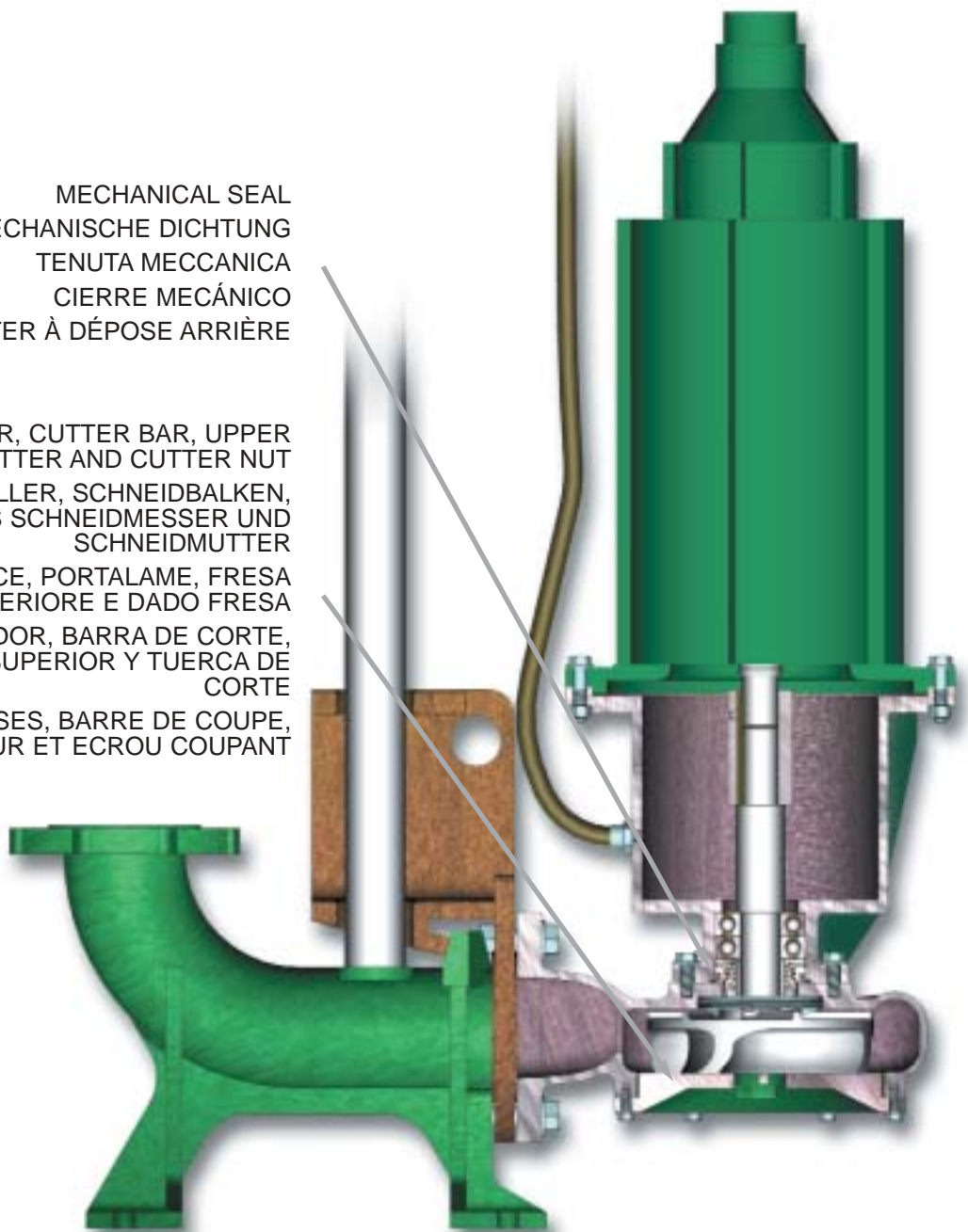

Hydraulic Submersible
Hydraulische Tauchpumpe
Idrauliche immergibili
Sumergible hidráulico
Submersible hydraulique



HYDRAULIC MOTOR
 HYDRAULIKMOTOR
 MOTORE IDRAULICO
 MOTOR HIDRÁULICO
 MOTEUR HYDRAULIQUE

OIL FILLED HOUSING
 ÖLGEFÜLLTER BEHÄLTER
 SCATOLA CUSCINETTI RIEMPITA DI OLIO
 ALOJAMIENTO LLENO DE ACEITE
 CARTER EMPLI D'HUILE

THRUST BEARINGS
 DRUCKLAGER
 CUSCINETTI REGGISPINTA
 COJINETES DE IMPULSO
 PALIERS DE BUTÉE

MECHANICAL SEAL
 MECHANISCHE DICHTUNG
 TENUTA MECCANICA
 CIERRE MECÁNICO
 CARTER À DÉPOSE ARRIÈRE

CHOPPER IMPELLER, CUTTER BAR, UPPER
 CUTTER AND CUTTER NUT
 CHOPPER-IMPELLER, SCHNEIDBALKEN,
 OBERES SCHNEIDMESSER UND
 SCHNEIDMUTTER
 GIRANTE TRITURATRICE, PORTALAME, FRESA
 SUPERIORE E DADO FRESA
 IMPULSOR TRITURADOR, BARRA DE CORTE,
 CORTADORA SUPERIOR Y TUERCA DE
 CORTE
 AUBES BROYEUSES, BARRE DE COUPE,
 COUPEAU SUPÉRIEUR ET ECROU COUPANT

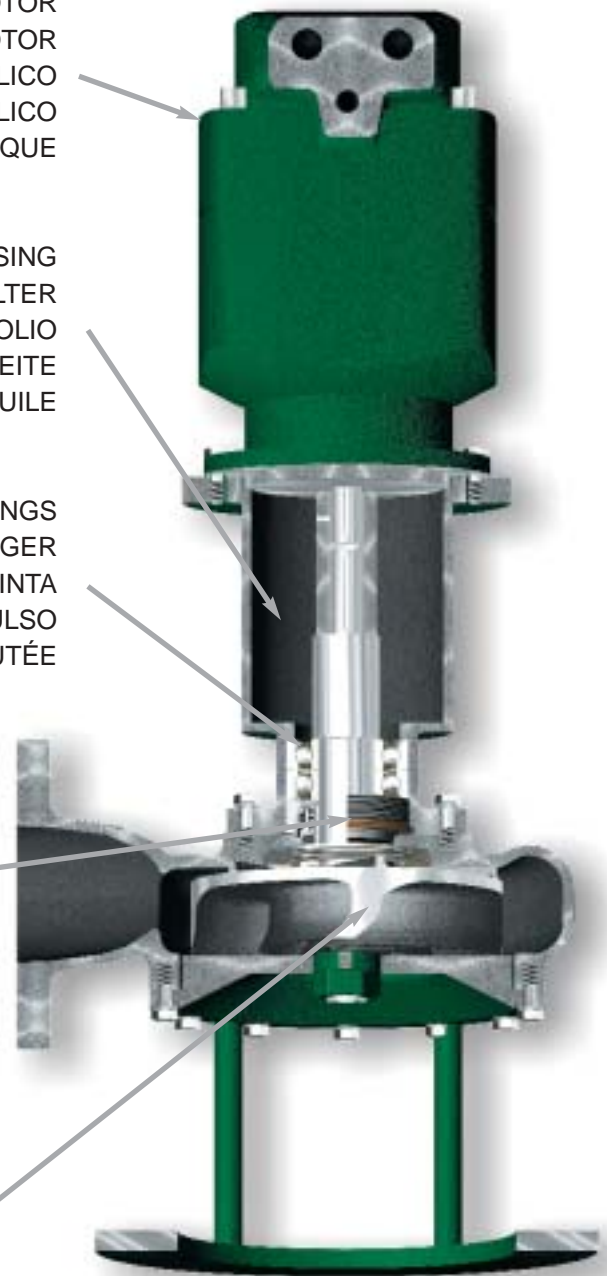



Vaughan

**Horizontal End Suction
Horizontale Aufstellung
Aspirazione Orizzontale
Aspiración horizontal
Horizontale**

**Dry Wells
Trockenaufstellung
Cassa asciutta
Pozos secos
Pompes en fosse sèche**

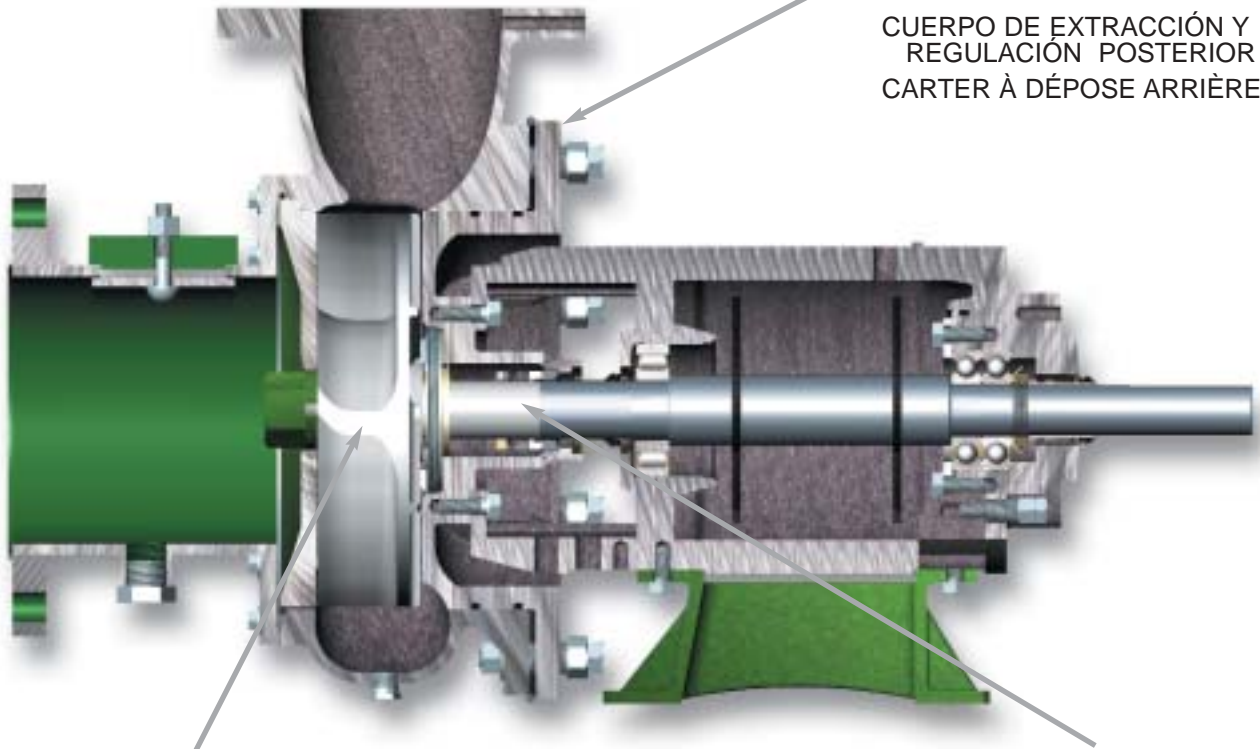

BACK PULL-OUT CASING
AUSZIEHBARES
RÜCKWÄRTIGES GEHÄUSE
CORPO A REGOLAZIONE
ESTERNA
CUERPO DE EXTRACCIÓN Y
REGULACIÓN POSTERIOR
CARTER À DÉPOSE ARRIÈRE

CHOPPER IMPELLER, CUTTER BAR, UPPER CUTTER AND
CUTTER NUT

CHOPPER-IMPELLER, SCHNEIDBALKEN, OBERES
SCHNEIDMESSER UND SCHNEIDMUTTER

GIRANTE TRITURATRICE, PORTALAME, FRESA SUPERIORE E
DADO FRESA

IMPULSOR TRITURADOR, BARRA DE CORTE, CORTADORA
SUPERIOR Y TUERCA DE CORTE

AUBES BROYEUSES, BARRE DE COUPE, COUPEAU SUPÉRIEUR
ET ECROU COUPANT

PACKING OR MECHANICAL SEAL
STOPF- ODER MECHANISCHE
DICHTUNG

BADERNA O TENUTA MECCANICA
EMPAQUETADURA O CIERRE
MECÁNICO

TRESSSES OU GARNITURE
MÉCANIQUE

Vertical Dry Pit
Vertikalpumpe in Trockenaufstellung
Verticali a cassa asciutta
Pozo seco vertical
Verticale en fosse sèche



THRUST BEARINGS
 DRUCKLAGER
 CUSCINETTI REGGISPINTA
 COJINETES DE IMPULSO
 PALIERS DE BUTÉE

OIL FILLED HOUSING
 ÖLGEFÜLLTER BEHÄLTER
 SCATOLA CUSCINETTI RIEMPITA DI OLIO
 ALOJAMIENTO LLENO DE ACEITE
 CARTER EMPLI D'HUILE

PACKING OR MECHANICAL SEAL
 STOPF- ODER MECHANISCHE DICHTUNG
 BADERNA O TENUTA MECCANICA
 EMPAQUETADURA O CIERRE MECÁNICO
 ÉTOUPE OU GARNITURE MÉCANIQUE

BACK PULL-OUT CASING
 AUSZIEHBARES RÜCKWÄRTIGES GEHÄUSE
 CORPO A REGOLAZIONE ESTERNA
 CUERPO DE EXTRACCIÓN Y REGULACIÓN POSTERIOR
 CARTER À DÉPOSE ARRIÈRE

CHOPPER IMPELLER, CUTTER BAR, UPPER CUTTER
 AND CUTTER NUT

CHOPPER-IMPELLER, SCHNEIDBALKEN, OBERES
 SCHNEIDMESSER UND SCHNEIDMUTTER

GIRANTE TRITURATRICE, PORTALAME, FRESA
 SUPERIORE E DADO FRESA

IMPULSOR TRITURADOR, BARRA DE CORTE,
 CORTADORA SUPERIOR Y TUERCA DE CORTE
 AUBES BROYEUSES, BARRE DE COUPE, COUPEAU
 SUPÉRIEUR ET ECROU COUPANT

CENTERLINE INLET AND DISCHARGE
 ZENTRALER EIN- UND ABLAUF
 ASPIRAZIONE E MANDATA SULLA LINEA CENTRALE
 ENTRADA E IMPULSIÓN LINEA CENTRO
 ASPIRATION ET REFOULEMENT SUR L'AXE

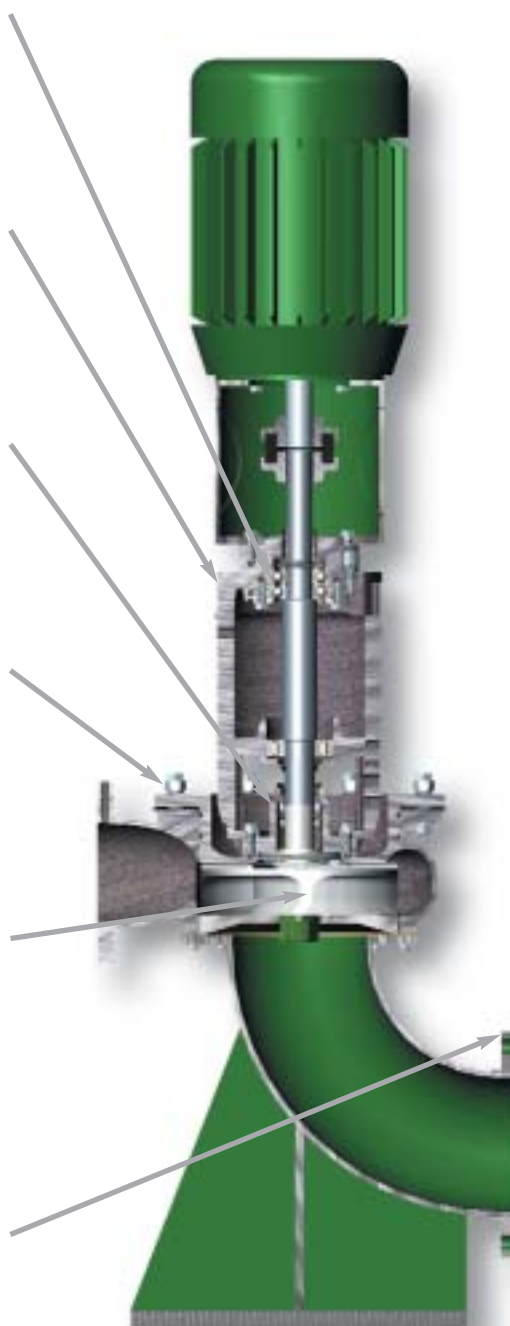



Vaughan

Self Primer
Selbstansaugend
Autoadescante
Autoaspirante
Auto - amorçante

Specialty Pumps
Spezialpumpen
Pompe speciali
Bombas especiales
Pompes spécifiques



REMOVABLE ROTATING ASSEMBLY
HERAUSNEHMBARE LAGEREINHEIT
GRUPPO ROTANTE RIMOVIBILE
CONJUNTO GIRATORIO EXTRAIBLE
ENSEMBLE ROTATIF AMOVIBLE

MECHANICAL SEAL
MECHANISCHE DICHTUNG
TENUTA MECCANICA
CIERRE MECÁNICO
GARNITURE MÉCANIQUE

OVERSIZED CLEANOUT
ÜBERGROSSE
REINIGUNGSÖFFNUNG
AMPIA APERTURA DI PULIZIA
BOCA DE LIMPIEZA DE GRAN
TAMAÑO
ORIFICE DE NETTOYAGE DE
GRANDES DIMENSIONS

CHOPPER IMPELLER, CUTTER BAR AND UPPER CUTTER
CHOPPER-IMPELLER, SCHNEIDBALKEN UND OBERES
SCHNEIDMESSER
GIRANTE TRITURATRICE, PORTALAME E FRESA SUPERIORE
IMPULSOR TRITURADORA, BARRA DE CORTE Y
CORTADORA SUPERIOR
AUBES BROYEUSES, BARRE DE COUPE ET COUPEAU
SUPÉRIEUR

OIL LUBRICATED THRUST BEARINGS
GESCHMIERTE DRUCKLAGER
CUSCINETTI REGGISPINTA LUBRIFICATI
AD OLIO
COJINETES DE IMPULSO LUBRICADOS
CON ACEITE
ROULEMENTS LUBRIFIES A L' HUILE

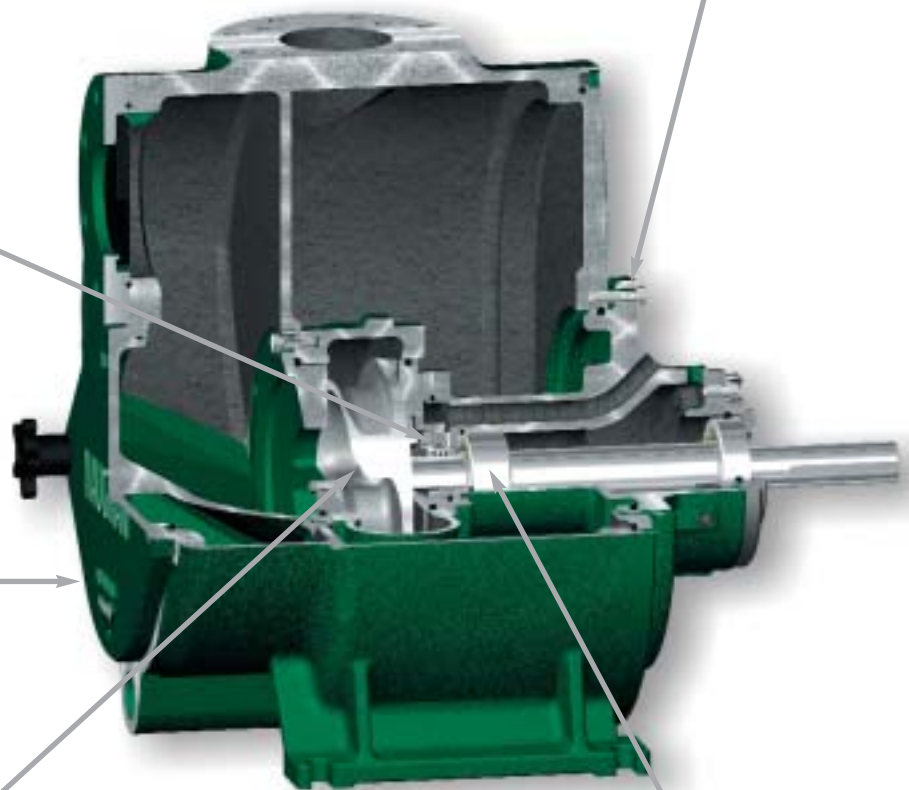

Recirculator Chopper Pumps
Rezirkulations-Chopper-Pumpe
Pompe trituratrici di riciclo
Bombas trituradoras de recirculación
Pompes broyeuses de recirculation

Vertical Recirculator
Vertikal-Rezirkulator
Ricircolatore verticale
Recirculador vertical
Verticale avec recirculation

Submersible Recirculator
Tauch-Rezirkulator
Ricircolatore immergibile
Recirculador sumergible
Avec recirculation submersible

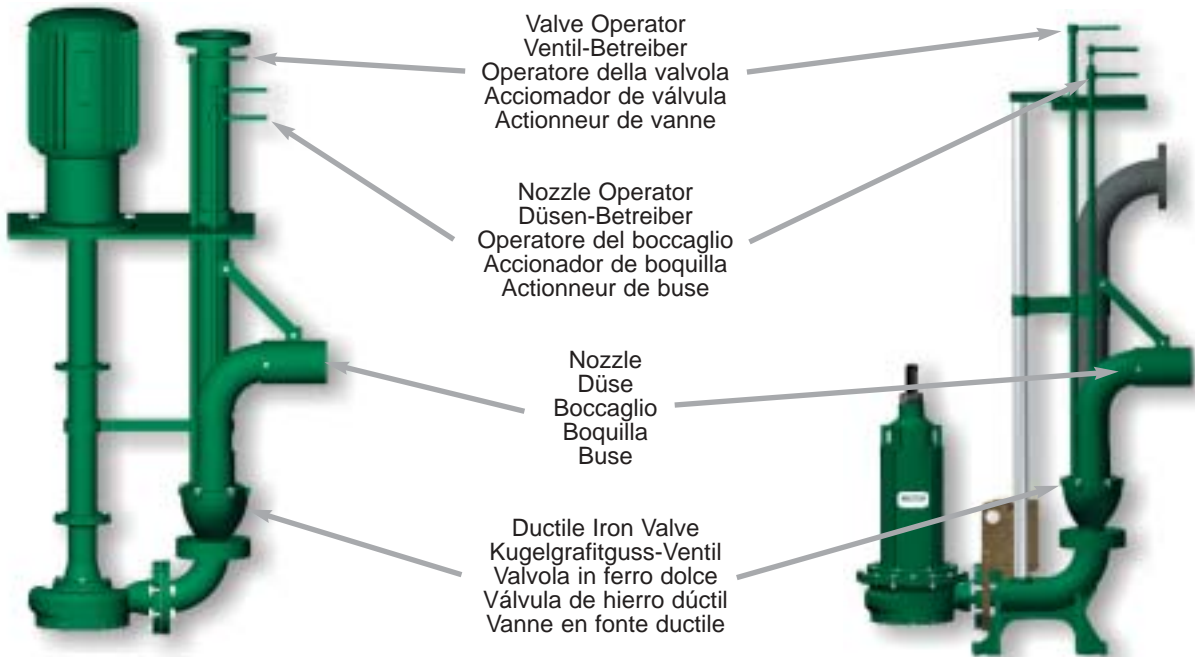

“Scumbuster” - Scum Mixer
“Scumbuster” - Schlamm-
Mischanlage
“Scumbuster” - Rompiscorie
Mezclador de Espumas
“Scumbuster”
Mélangeur d'écume
«Scumbuster»

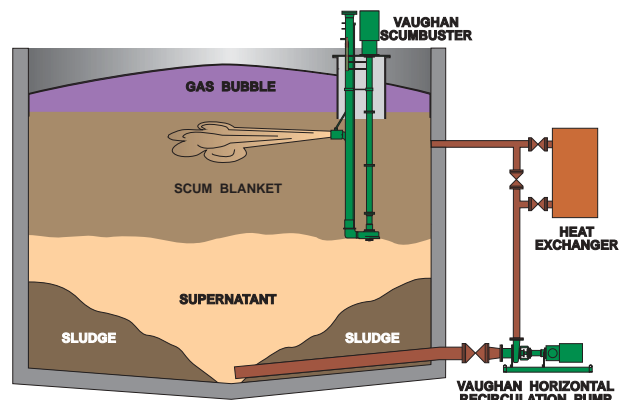



Vaughan

Applications

Anwendungsbereiche

Applicazioni

Aplicaciones

Utilisations

Municipal Applications
Städtische Anwendungsbereiche
Applicazioni municipali
Aplicaciones municipales
Utilisations municipales

1. LIFT STATIONS
ABWASSER-STATIONEN
STAZIONI DI SOLLEVAMENTO
ESTACIONES DE BOMBEO
POSTES DE RELÈVEMENT
2. SEPTAGE RECEIVING
ABWASSER-SAMMELANLAGE
RICEZIONE DI FOSSE SETTICHE
RECEPCIÓN DE RESIDUOS SÉPTICOS
RÉCEPTION DES BOUES DES FOSSES SEPTIQUES
3. SLUDGE TRANSFER
SCHLAMM-FÖRDERUNG
TRASFERIMENTO DI SEDIMENTI
TRANSFERENCIA DE FANGOS
TRANSFERT DE BOUES
4. SLUDGE MIXING
SCHLAMM-MISCHUNG
MISCELAZIONE DI SEDIMENTI
MEZCLA DE FANGOS
MÉLANGE DE BOUES
5. DIGESTER SCUM BLANKETS
DIGESTIER-SCHLAMMDECKEN
MANTI DI SCORIE DEL DIGESTORE
MANTOS DE ESPUMA DEL DIGESTOR
ECUME DES DIGESTEURS
6. DIGESTER MIXING
DIGESTIERSCHLAMM-MISCHUNG
MISCELAZIONE DEL DIGESTORE
MEZCLA DEL DIGESTOR
MÉLANGE DES DIGESTEURS
7. DIGESTER RECIRCULATION
DIGESTIERSCHLAMM-REZIRKULATION
RICIRCOLAZIONE DEL DIGESTORE
RECIRCULACIÓN DEL DIGESTOR
RECIRCULATION DES DIGESTEURS
8. CLARIFIER SCUM PITS
KLÄRSCHLAMMGRUBEN
PULIZIA DELLE SCORIE NEI BACINI
POZOS DEL CLARIFICADOR DE ESPUMA
POMPAGE DE SURVERSE DE CLARIFICATEUR

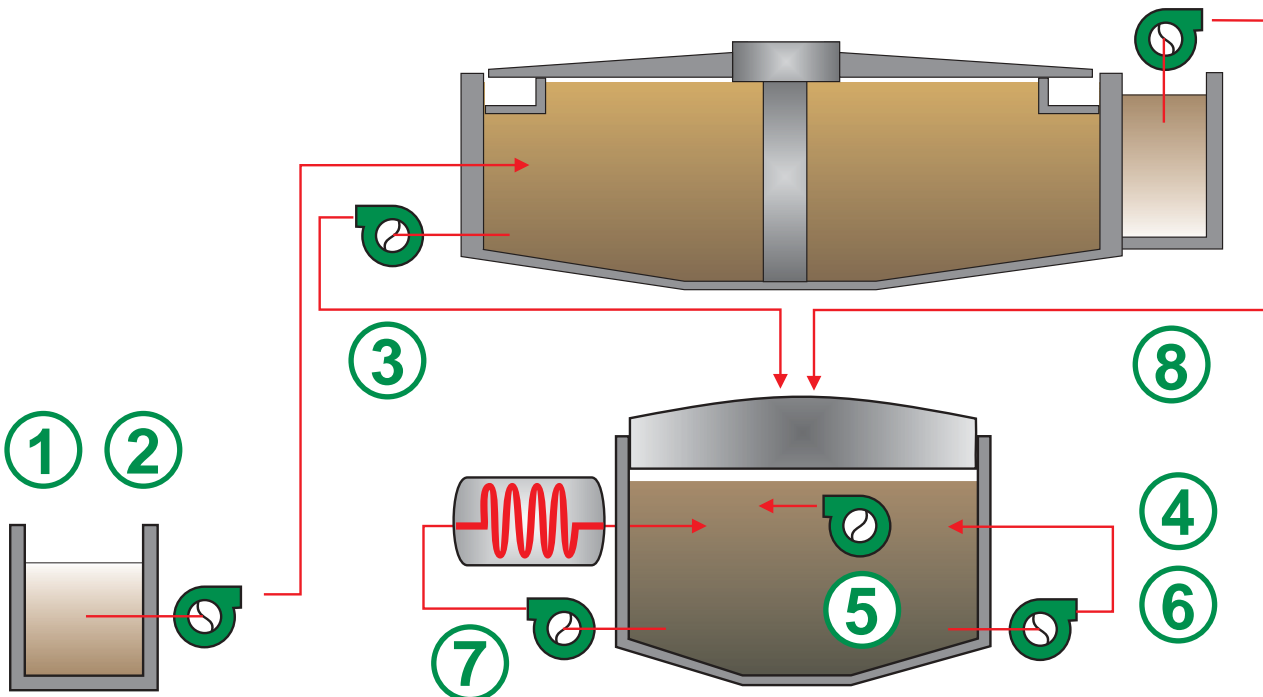

Industrial Applications Industrielle Einsatzbereiche Applicazioni industriali Aplicaciones industriales Utilisations industrielles

Paper / Wood Products
Papier- / Holzprodukte
Prodotti di carta e legno
Productos de papel y madera
Papeteries



Food Processing
Lebensmittelverarbeitung
Settore alimentare
Procesado de Alimentos
Agro-alimentaire



Automotive / Steel
Automobil / Stahl
Settore
automobilistico/siderurgico
Automoción - acero
Construction
automobile/Sidérurgie



Chemical
Chemie
Industria chimica
Industria Química
Industrie chimique



Mining / Sand & Gravel
Bergbau / Sand & Kiesel
Minerali, sabbia e ghiaia
Minería - arena y grava
Mines / Carrières



Contractor Services
Unternehmer-Dienstleistungen
Servizi in appalto
Servicios par Contratistas
Travaux Publics

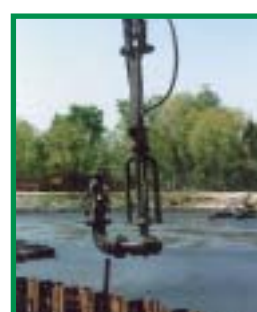



Chopper Pumps - Wet Wells, Dry Wells, Submersibles, Self-Primers, Recirculators
Chopper-Pumpen - Nassaufstellung, Trockenaufstellung, Tauchpumpen, Selbstansaug-Pumpen, Rezirkulationspumpen
Pompe Trituratrici - Casse bagnate, Casse asciutte, Immergibili, Autoadescanti, Ricircolo
Bombas Trituradoras - Pozos Húmedos, Pozos Secos, Sumergibles, Autoaspirantes, Recirculadores
Pompes Broyeuses - Puits de Pompage, Puits Secs, Submersibles, Pompes à Amorçage Automatique, Recirculateurs

Also Available - Floating Pumps, Lagoon Pumpers, Mixers, Auger Choppers, Vortex Choppers, Veggie Choppers.
Ebenso lieferbar - Plattformpumpen, Lagunenpumpen, Mischanlagen, Schnecken-Chopper, Wirbel-Chopper, Gemüse-Chopper
Sono anche Disponibili - Pompe Flottanti, Pompaggio per Lagune, Miscelatori, Pompe Trituratrici a Coclea, Pompe Trituratrici a Vortice, Trita Verdura
También están Disponibles: Bombas Flotantes, Bombas Para Lagunas, Mezcladoras, Picadoras de Barrena, Trituradoras de Vórtice, Trituradoras de Verduras
Aussi Disponibles - Pompes Flottantes, Pompes de Bassin, Mélangeurs, Broyeurs à vis sans fin, Broyeurs à Tourbillon, Broyeurs de Légumes

Vaughan Company, Inc.

U.S. HOME OFFICE:

364 Monte Elma Road
Montesano, WA USA 98563
PHONE: 1-360-249-4042
FAX: 1-360-249-6155
<http://www.chopperpumps.com>
U.S. E-MAIL: info@chopperpumps.com
INTERNATIONAL E-MAIL: intl@chopperpumps.com

U.S. PATENTS: No. 5,460,483; No. 5,460,482; No. 5,456,580; No. 5,256,032; No. 5,076,757; No. 4,840,384; No. 4,842,479; No. 3,155,046; No. 3,973,866; No. 3,774,323.

INTERNATIONAL PATENTS: No. 94/7561; No. 1,274,886; No. 910,127; No. 698,327; No. 1,040,006; No. 178,507; No. 539,722; No. 1,531,025; No. 1,193,483; No. 1,193,484; No. 1,193,485; No. 1,193,486; No. 498,063; No. P26 18 559; No. 512,380; No. 1,172,906; No. 963,918; No. 1,290,981; No. 687476; No. 276224; No. 75,941; No. 3480.

OTHER PATENTS PENDING.



FORM V376, REV. 2, 4/03
EUROPEAN MULTI-LANGUAGE