



## 8" & 10" SELF-PRIMING CHOPPER PUMPS



- ✓ Largest Self-Priming Chopper
- ✓ Highest Efficiency - 70% BEP
- ✓ Highest Flow - 6000 GPM
- ✓ Highest Reprime - 22 Feet
- ✓ Heaviest Design - 3000 LB.
- ✓ Externally Adjustable Clearances
- ✓ Independent Casing & Housing
- ✓ Glass Lining Available
- ✓ Hardened Ductile Iron Available
- ✓ All Parts In-Stock

**Model SP8N  
REPRIME LIFT**

RPM	LIFT (FT)
1185	22
1170	21
1065	20
970	19
930	18
885	15
860	14
785	12
740	11
700	10
650	9
615	8
500	7

CURVE	POWER (HP/KW)	SPEED (RPM)	IMPELLER DIAMETER
A	125/90	1185	16.00" (406 mm)
B	100/75	1170	16.00" (406 mm)
C	75/55	1065	16.00" (406 mm)
D	60/45	970	16.00" (406 mm)
E	50/37	930	16.00" (406 mm)
F	50/37	885	16.00" (406 mm)
G	40/30	860	16.00" (406 mm)
H	30/22	785	16.00" (406 mm)
I	25/18.5	740	16.00" (406 mm)
J	25/18.5	700	16.00" (406 mm)
K	20/15	650	16.00" (406 mm)
L	15/11	615	16.00" (406 mm)
M	15/11*	500	16.00" (406 mm)

**Model SP10R  
REPRIME LIFT**

RPM	LIFT (FT)
1185	22
1150	21
1045	20
970	19
870	18
845	17
750	16
700	16
650	15
500	12

CURVE	POWER (HP/KW)	SPEED (RPM)	IMPELLER DIAMETER
A	125/90	1185	16.00" (406 mm)
B	100/75	1150	16.00" (406 mm)
C	75/55	1045	16.00" (406 mm)
D	60/45	970	16.00" (406 mm)
E	50/37	870	16.00" (406 mm)
F	40/30	845	16.00" (406 mm)
G	30/22	750	16.00" (406 mm)
H	25/18.5	700	16.00" (406 mm)
I	20/15	650	16.00" (406 mm)
J	15/11*	500	16.00" (406 mm)

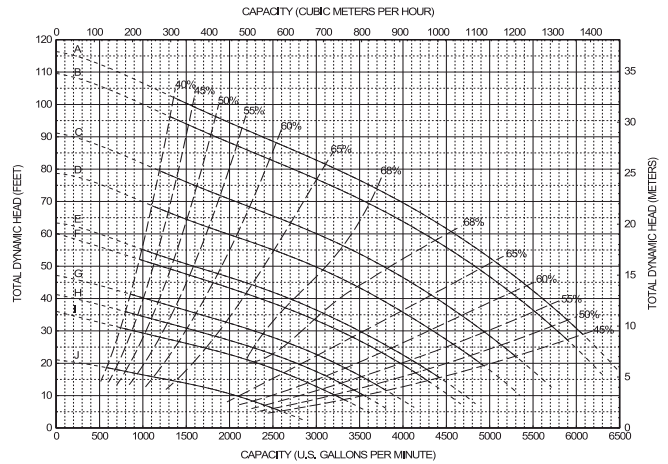
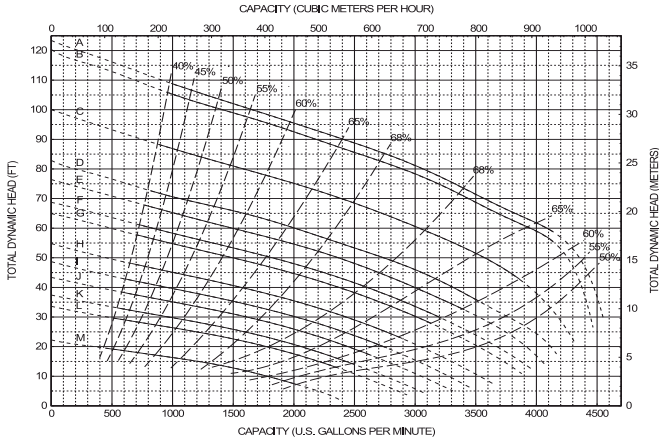

**DIRECT DRIVE**

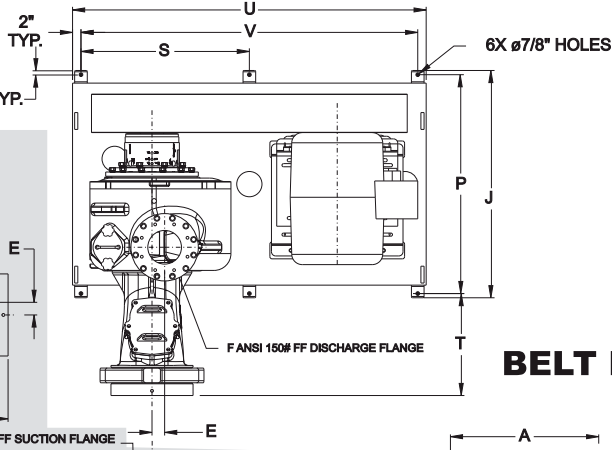
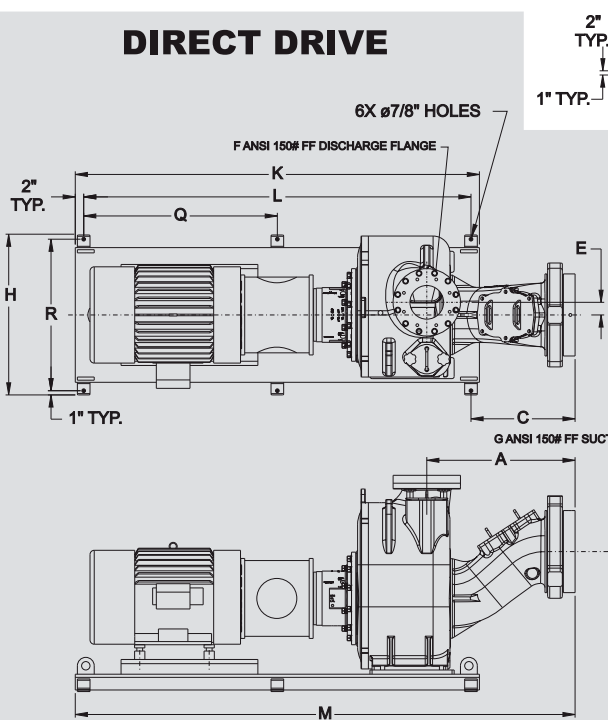

**BELT DRIVE**

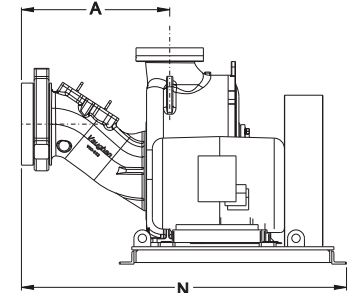

**DIRECT DRIVE**

MODEL	A	B	C	D	E	F	G
SP8N	35 1/4	33 1/4	24 3/4	16 1/4	3	8	10
SP10R	35 1/4	33 1/4	24 3/4	18 1/8	3	10	12

MODEL	H	K	L	M	Q	R
SP8N	38 3/16	96	92	118 3/4	46	36
SP10R	38 3/16	96	91	118 3/4	46	36

**BELT DRIVE**

MODEL	A	B	D	E	F	G	J
SP8NB	35 1/4	33 1/4	16 1/4	3	8	10	54
SP10RB	35 1/4	33 1/4	18 1/8	3	10	12	54

MODEL	N	P	S	T	U	V
SP8NB	77 1/4	52	40	24 1/4	84	80
SP10RB	77 1/4	52	40	24 1/4	84	80

**Vaughan Co., Inc.**

364 Monte Elma Road, Montesano, WA 98563  
 Phone: (360)249-4042, FAX: (360)249-6155  
 Toll Free: (888)249-CHOP  
 www.chopperpumps.com  
 e-mail: info@chopperpumps.com