

Piston pumps for efficient wellpoint dewatering

PT series



Pumps for results



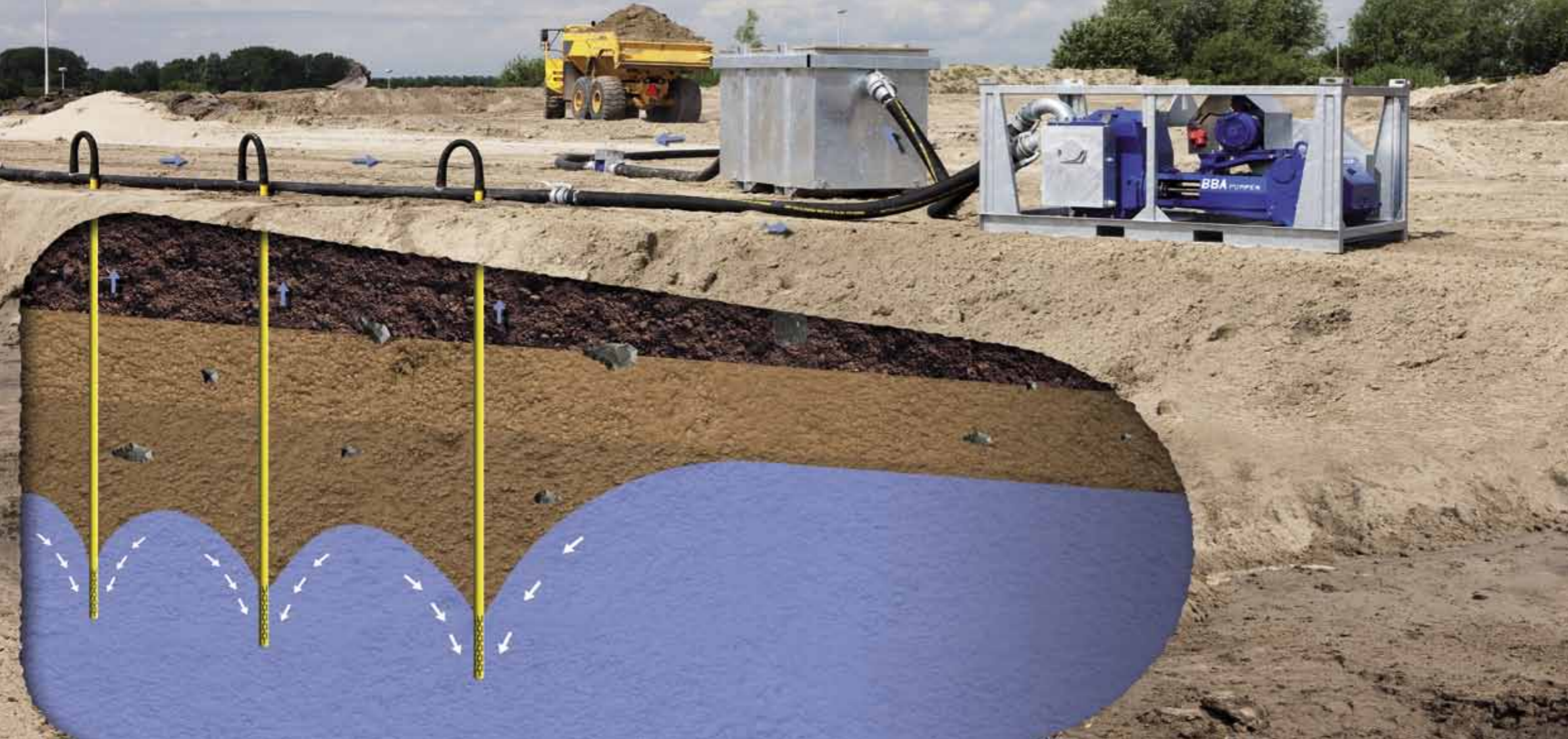

Innovative leaders for the past 60 years

BBA Pumps BV wouldn't be a Dutch company if it didn't know how to deal with water! We've been helping our customers keep their feet dry for over sixty years: we use our knowledge and experience in dewatering and rental to create high-quality products and solutions together with our customers. Innovation is our strength: we are constantly working on new techniques and technologies so we can set the trend in wellpoint dewatering, using top quality pumps.

An investment that pays for itself

With the PT piston pumps, BBA Pumps offers a unique range of double-action piston pumps that more than pay for themselves. The PT Economy® model is truly unique: the new DriveOn® engine concept developed in cooperation with Hatz Diesel substantially increases the service interval.

The PT piston pump offers you:

- Lowest fuel consumption
- Lowest cost of ownership
- Longest life time
- Best reliability



The heart of the matter

The combination of high quality and smart solutions makes the PT piston pump an outstanding, reliable and modern pump.



Lubrication and drive
A smart lubrication system and the gear technology in the pump's drive section reduce the noise level and improve performance.



Practical valve system
The valve system is equipped with an O-ring seal and a solid bridge section for securing purposes. This allows for quick and easy disassembly, even after long running times.



Corrosion free
The stainless steel studs and bronze cover nuts guarantee easy disassembly and a long life.

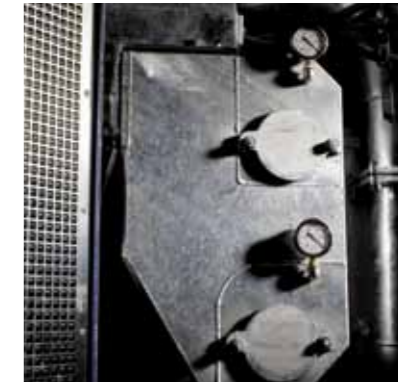

Standard stone catcher
The stone catcher, installed as a standard feature, has practical cleaning covers. Depending on the version, the pump comes with a double vacuum meter.

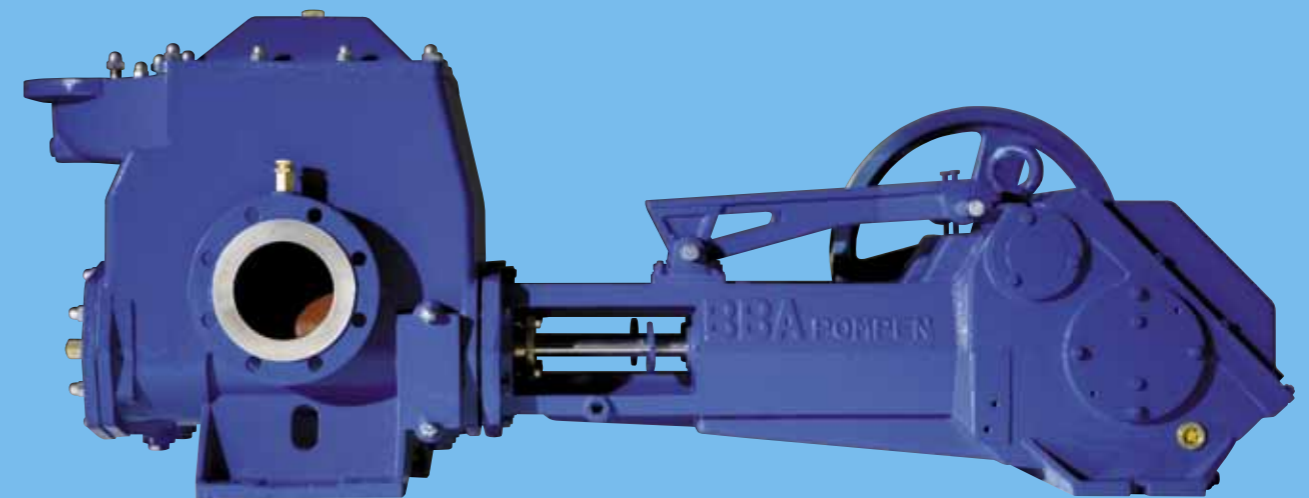
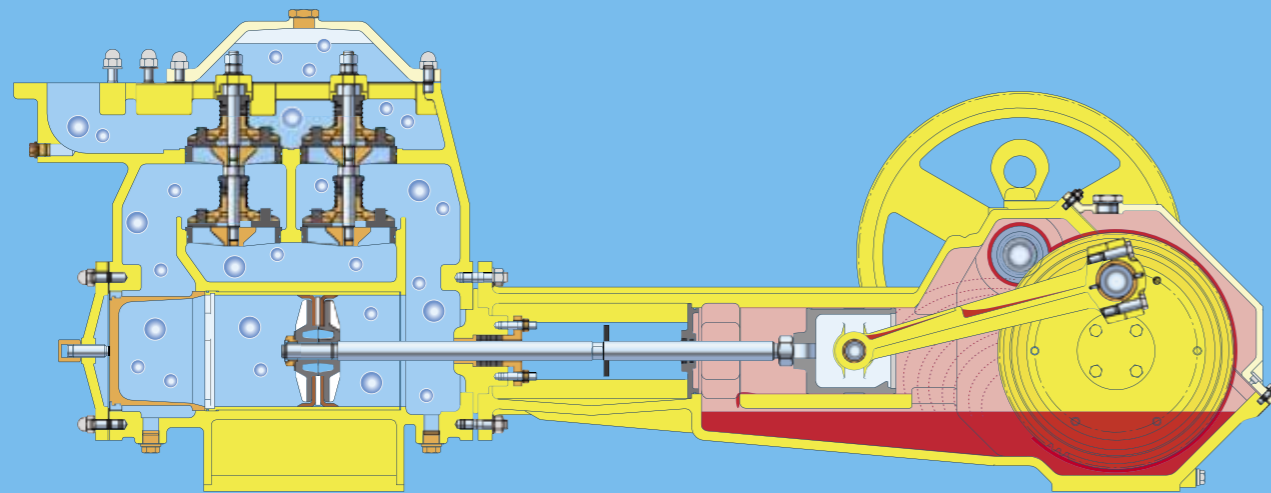

Practical cleaning cover
Dirt is removed from the cylinder area by simply lifting the cleaning cover. Changing the gland packing—usually a cumbersome task—is child's play.



Very robust piston rods
The stainless-steel piston rods have been carefully grinded to guarantee maximum service life.



Durable cylinder bushes
The heavy stainless-steel cylinder bushes are easily rotated by hand using a bayonet system. The sturdiness of the material and the ability to rotate the bushes triples their service life.



Handy covers
The aluminum covers on the carter side allow optimal heat transfer without condensation. During maintenance, the covers are easy to grip, lift, and move.



PT open diesel

The open frame PT series is also available with a diesel engine. This unsilenced version is mainly used in non-urban areas.

The pump is driven by an energy efficient one-cylinder Hatz diesel engine that is also available in the "Silent Pack" version. The frame's protection bars protect the unit from external damage at the construction site.

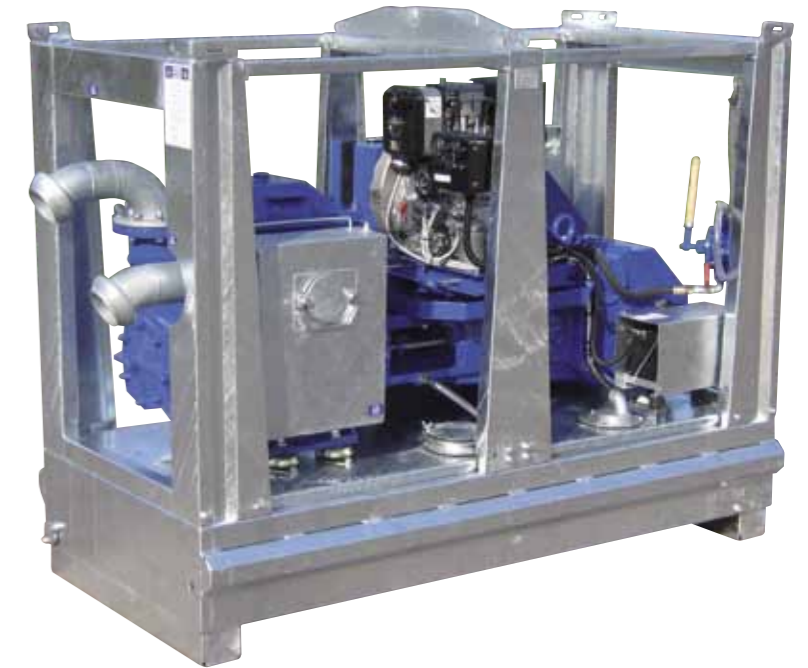

PT electric drive

The electrically driven PT pumps are the classic example of a simple pump concept.

The robust PT pump is installed in a stable galvanized stackable frame, which protects it and guarantees a life of several decades.

The pump set is equipped with an efficient electric motor and a manually operated star delta switch. A rain cover protects the motor from weather influences. Our extensive knowledge and experience of energy-efficiency pumps enables us to advise you on how to achieve the best results, for example, by using frequency drive or level control.





The proof

- Consumes less than 1.5 l of fuel/hr (0.4 US gallons/hr).
- Fuel tank autonomy approx. 1 week.
- Noise level 49 dB(A) at 10 meters.
- Entirely oil-spillage and leakage-free system.
- Built-in bunded fuel tank and oil/water separator.

PT 60/90 B-compact

The B-compact has proven itself around the world as the most reliable and cost saving wellpoint dewatering pump. The remarkable details of the simple pump concept are what make the pump successful.

Our years of experience in the Dutch dewatering market have enabled us to develop a light, compact, super-silent pump set with a number of outstanding technical features.

The pump's standard version is prepared for the installation of a GPS system, with or without digital flow meter.



Protection bars for durable look and service life.

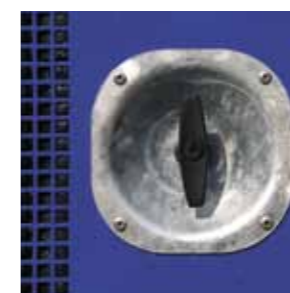

Lockable "T-Locks" for good grip and durability.



Heavy duty stainless-steel hinges with lubrication points.



180 liter PE diesel reservoir.



Aluminum top and front cover.



Easy to transport and store. Two compact pumps can be loaded crosswise on a truck, and even stacked.



The standard version of the pump is prepared for the installation of a digital flow meter.



Gland water and drainage water is automatically caught and disposed by means of a bund.



The proof

- Service only every 1,500 hours.
- Uses 35% less oil.
- Uses* 5% less fuel.
- Pit-stop service times.

*) Compared with earlier PT models, fuel savings are substantially higher when compared with centrifugal pumps used for the same application.

Unique engine concepts

Lower costs, more ergonomic, environmentally friendly.

Close collaboration between the R&D departments of BBA Pumps and Hatz has led to the development of a revolutionary engine concept. Redesigning the oil sump system and modifying the engine's entire filter system (oil, fuel and air) resulted in a product with an excellent service interval: the patented DriveOn system has a service interval of 1,500 hours with full Hatz factory warranty. This results in extensive cost savings. In addition, all of the service points are located at one side of the engine for optimal ergonomics and pitstop-like service times!



Caring for the environment

The PT series not only enables you to reduce costs, it also helps you care for the environment. Made of durable materials, the pumps are designed to prevent spillage or leakage, and to perform at high levels using very little energy.





The proof

- Consumes less than 1.5 l of fuel/hr (0.4 US gallons/hr).
- Service interval of 1,500 hours.
- Fuel tank autonomy approx. 2 weeks.
- Noise level 49 dB(A) at 10 meters.
- Entirely oil-spillage and leakage-free system.
- Built-in bunded fuel tank and oil/water separator.

PT Economy[®]



The PT Economy[®] pump is based on the PT B-Compact concept, which has already proven itself around the world. Despite its 300-liter tank, the PT Economy[®] is relatively lightweight.

The built-in Hatz DriveOn[®] engine increases the service interval, reduces fuel consumption, and is ergonomic and environmentally friendly.



Minimum space for storage and transport.



Lower fuel consumption thanks to timing belt drive.



Needs 50% less refueling; no oxidation.



Longer running time without downtime for maintenance.



Easily accessible.



Pumps for the future

With our PT pumps, you're all set for the future. Our innovative and environmentally friendly concepts are aimed at ease of use and reducing costs. We are always on the lookout for new techniques and technologies, just as you would expect from a company aspiring to set the trend in wellpoint dewatering.



Remote control

The PT Economy® and the B-Compact are prepared in the factory for the installation of a digital flow meter and a GPS/GSM monitoring system, meaning that either or both are easily installed when needed. The monitoring system gives you 24-hour control over the pump from behind your PC or by means of text messages sent to your cell phone. The benefits:

- Daily flow meter readings directly to your PC
- Faults reported as text messages
- GPS prevents theft
- Cost savings

Bare shaft pumps		PT 130	PT 60	PT 90	PT 250
PT bare shaft					
Capacity	m ³ /hr	35	65	90	190
	GPM	154	286	396	837
Discharge head	mwc	20	20	20	20/30
	Feet	65	65	65	65/98
Max. suction lift	mwc	9,6	9,6	9,6	9,6
	Feet	32	32	32	32
L x W x H	mm	1483 x 640 x 580	2000 x 650 x 765	2000 x 650 x 765	2000 x 1080 x 940
Weight	kg	350	815	815	1240

Electric pumps					
PT electric					
Power	kW	3,0	5,5	7,5	11 , 15
Connections	inch	4"	4"	4/6"	2 x 6/8"
Base frame					
L x W x H	mm	1500 x 700 x 1015	2000 x 890 x 1145	2000 x 890 x 1145	2100 x 1100 x 1480
Weight	kg	575	1140	1140	1840
Stackable frame					
L x W x H		2200 x 1060 x 1044	2200 x 1060 x 1044	2200 x 1060 x 1044	2500 x 1200 x 1900
Weight	kg	750	1200	1200	2500
PT electric in canopy					
L x W x H	mm	1620 x 800 x 1210	2250 x 1050 x 1250	2250 x 1050 x 1250	2500 x 1200 x 1900
Weight	kg	870	1485	1485	2900

Diesel pumps					
Hatz engine		1D41Z	1D81Z	1D81Z	2M41
Engine power	kW	2,6	5,8		16
Connections	inch	4"	4"	6"	8"

PT open diesel					
Fuel capacity	ltr	95	180	180	300
	gal (US)	25	40	40	79
L x W x H	mm	2200 x 700 x 1000	1800 x 900 x 1600	1800 x 900 x 1600	2500 x 1200 x 1900
Weight	kg	900	1600	1600	3100

PT B-Compact canopy					
Fuel capacity	ltr	95	180	180	300
	gal (US)	25	48	48	79
L x W x H	mm	1800 x 900 x 1325	2250 x 1050 x 1545	2250 x 1050 x 1545	2500 x 1200 x 1900
Weight	kg	1100	1855	1855	3400

PT Economy canopy					
Fuel capacity	ltr	X	300	300	X
	gal (US)	X	79	79	X
L x W x H	mm	X	2250 x 1050 x 1740	2250 x 1050 x 1740	X
Weight	kg	X	2135	2135	X

Weights include full fuel tank.



PT electric base frame



PT electric stackable frame

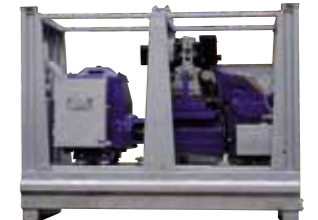

PT open diesel



PT B-compact canopy

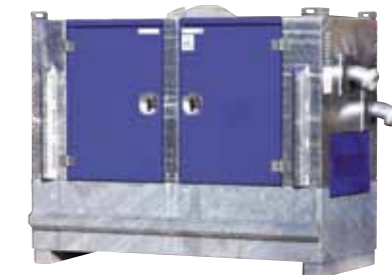

PT Economy canopy

BBA Pumps BV

Edisonstraat 12
Postbus 498
7000 AL Doetinchem
The Netherlands

p +31 (0)314-368 436
f +31 (0)314-378 403
e info@bbapumps.com
i www.bbapumps.com

